

High-precision Visual Displacement Measurement System

# Z300

*2-Dimensional CCD is Built in. A New Type of Displacement Sensor Utilizing the Best and Most Up-to-date Image Processing Technologies.*

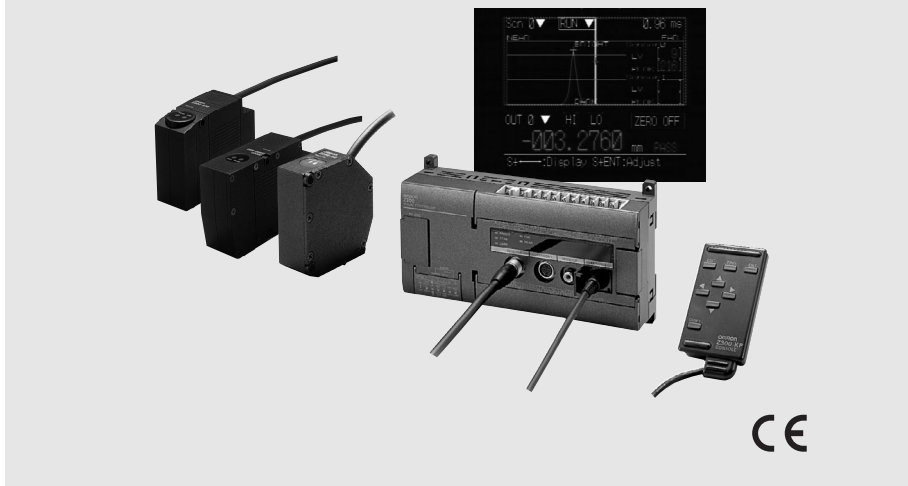

Z300

## Features

Stable measurement of a transparent object or a glass.

A wide variety of sensor heads for enhanced detection possibilities.

OMRON's Z300 makes the notion that displacement sensors cannot perform stable measurement of a transparent object or a glass a thing of the past. The newly-developed 2-dimensional CCD (S-CCD) incorporated in the Z300, combined with upgraded performance of the controller, provides enhanced stability and accuracy in measurement of a transparent object. The latest algorithm employed by the Z300 enables optimal sensitivity even if there is a big difference between the amount of reflected light from the surface and that from the bottom of a glass.

Enhanced measurement area and a variety of high-resolution, long-distance sensor heads greatly expand the range of applications.

The Z300 is just another example of OMRON's ongoing challenge to the limits of sensing possibilities.

Z300-S60  
Super Long-range Model  
Detection distance of  $600 \pm 350$  mm

Z300-S10  
Long-range Model  
Detection distance of  $100 \pm 20$  mm

Z300-S5T  
High-precision Model  
Detection distance of  $50 \pm 5$  mm

Z300-S2T  
Super-precision Model  
Detection distance of  $20 \pm 1$  mm

The innovative 2-dimensional CCD (S-CCD) is the key to the sensing performance.

The 2-dimensional CCD enables stable, high-speed measurement.

A conventional displacement sensor using a 1-dimensional CCD cannot deal with flutter influence to the output. Therefore, the sensor requires increased number of measurements for signal averaging, which leads to slow response time. The S-CCD with a 2-dimensional CCD has solved this disadvantage, by splitting the measurement point into 60 lines for measurement in finer detail. The value per each pixel is then averaged to produce a reliable output, free from flutter influence caused by the object's surface condition. Stable detection and high-speed processing is thus possible with the Z300.

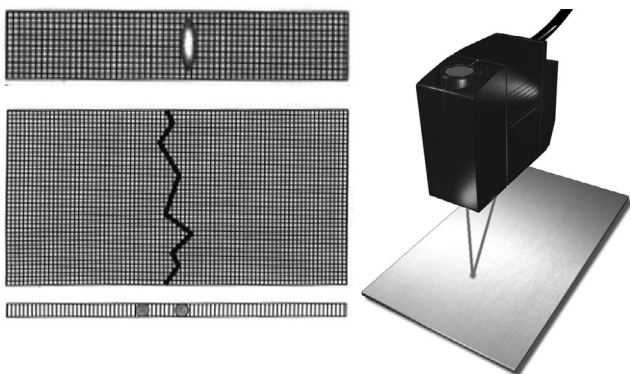

CCD makes a difference in measurement of a transparent object.

PSD sensor

A PSD sensor using diffuse reflection is virtually prevented from performing measurement due to insufficient reflection distribution from the surface. A sensor using the mirror reflection method, on the other hand, receives reflective light from the bottom or background of the object, which causes an error in determining the target position, impeding accurate measurement.

CCD sensor

A CCD using the mirror reflection method is a solution. It can extract only the light reflected off the surface of the target. Accurate measurement of a transparent object is possible without being affected by reflected light from the bottom or background of the object.

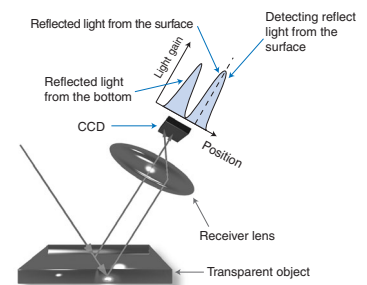
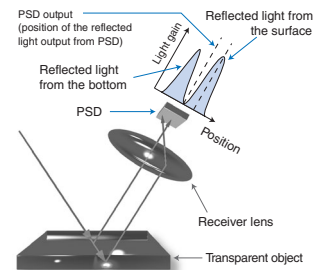

**Monitoring as the object is being measured.  
Measurement data can be recorded and played back.**

Easy-to-see color display is another great feature of the Z300 (when connected to a color monitor). Monitoring at each key stage including test and adjustment, operation, or maintenance greatly facilitates efficient, error-free measurement.

**Real-time monitoring**

**Digital monitor**

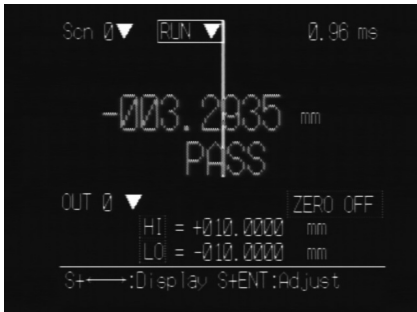

The measured value is displayed. The use of two colors: green for "Pass" judgement, and red for "High/Low," enhances visual recognition of the measurement result.

**Image monitor**

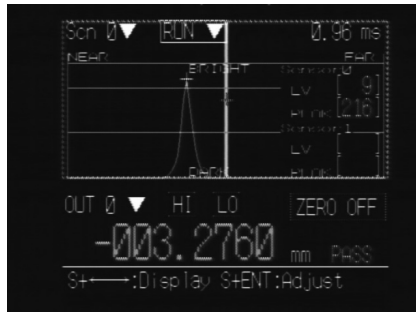

Displays the position of measurement point as well as intensity of the reflected light. Conveniently checks whether optimum measurement is taking place.

**Trend monitor**

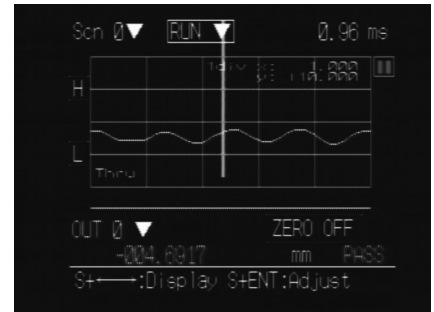

Continuous measurement values during a certain period of time are shown in chronological order. Changes in the measured values of a moving or rotating object can be checked at a glance.

Z300

**Monitoring during recording and playback**

**Test mode**

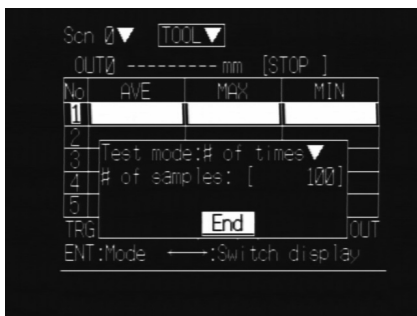

Any desired number of measurement data can be stored for testing with a workpiece.

**Conditions during Test mode can be recorded and played back**

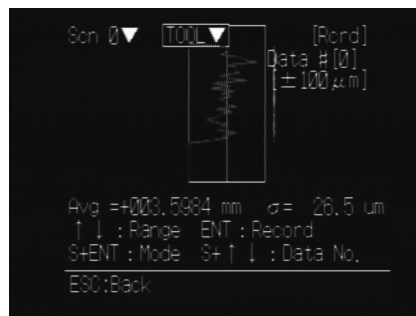

Test measurement data obtained off-line can be saved for reference for actual in-line measurement.

**NG (High/Low) judgement status is recorded and played back.**

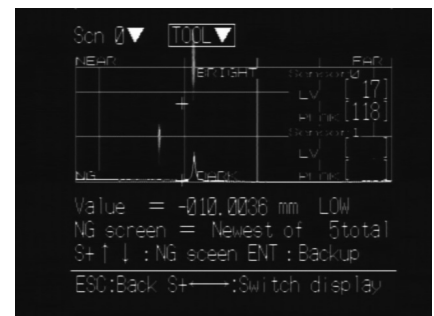

Up to 20 in-line NG data (information including reflected light condition and measurement data) can be recorded for workpiece analysis as well as for troubleshooting.

## Interactive menus provide a variety of measurement functions.

### Application menu

Settings for measurement methods are easily performed using the menu.

Just follow the guidance of the monitor screen.

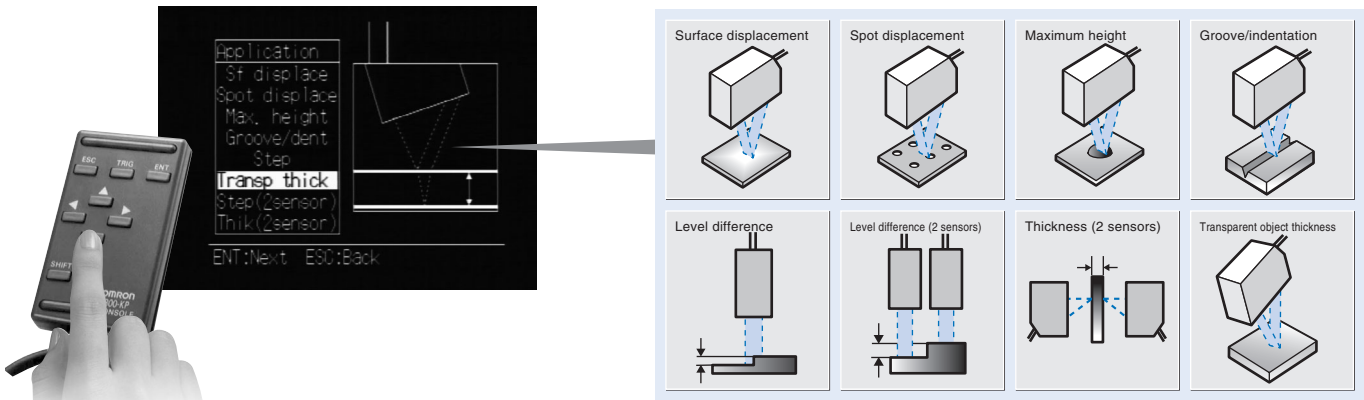

### Expert menu

Expert menu is available for more advanced measurement. Detailed setting conditions can be conveniently programmed using the menu.

## Enhanced hold functions widen the scope of application.

With discrete hold functions equipped within the controller, the Z300 provides a variety of trigger (measurement timing) functions, making otherwise difficult applications a reality — with ease.

### Hold functions

#### Sampling hold

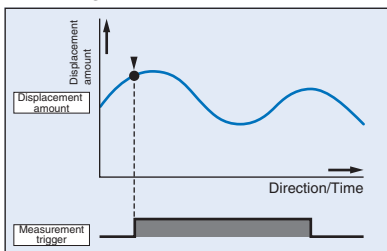

#### Peak hold (bottom)

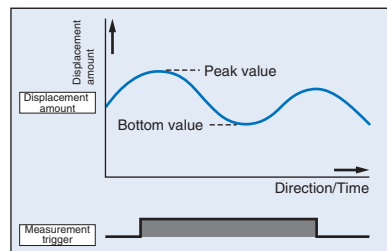

#### Peak to peak hold

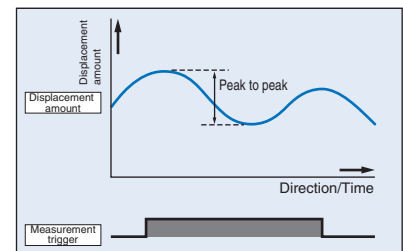

#### Average hold

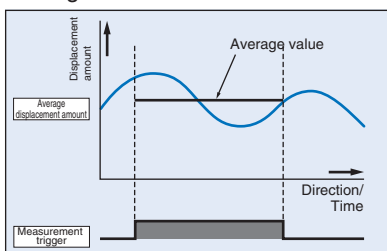

#### Length hold

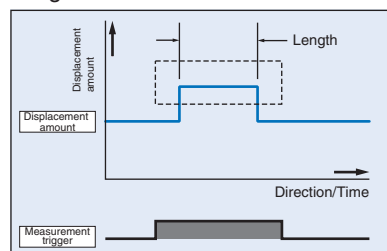

### Selectable trigger function

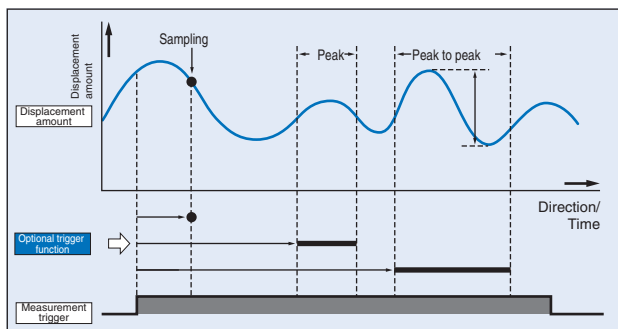

Measurement trigger can be set to the controller for desired measurement timing.

Application

Measuring the thickness of transparent film

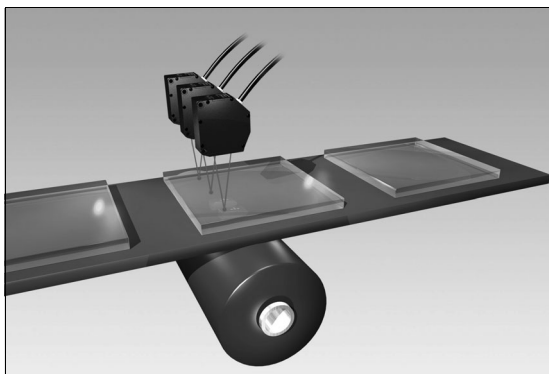

Measurement of electrode position in the display module

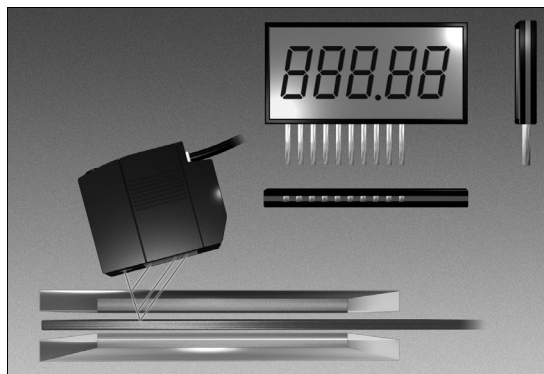

Measuring the thickness of sheet

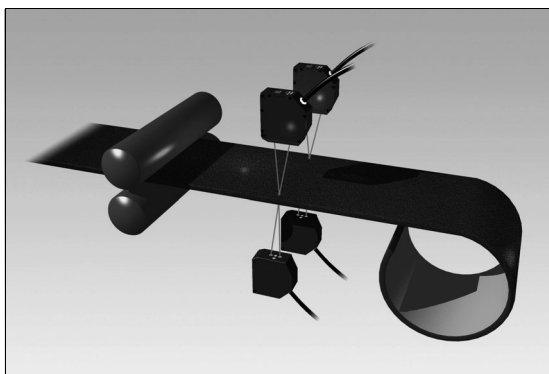

Measurement of warping in transparent plastic

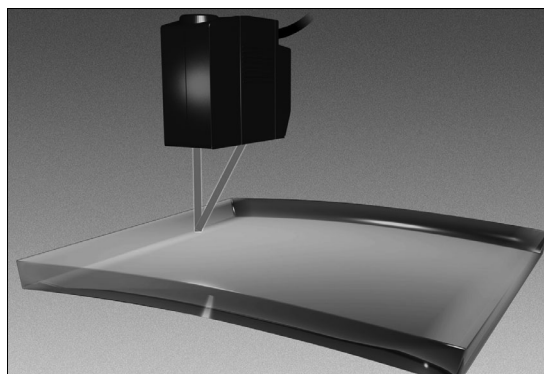

Inspecting the surface uniformity of a hard disk

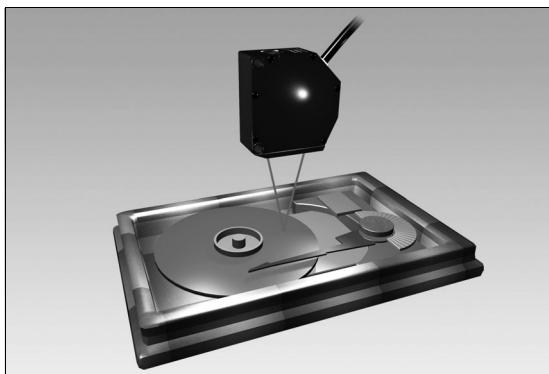

Shape measurement for welding robot control

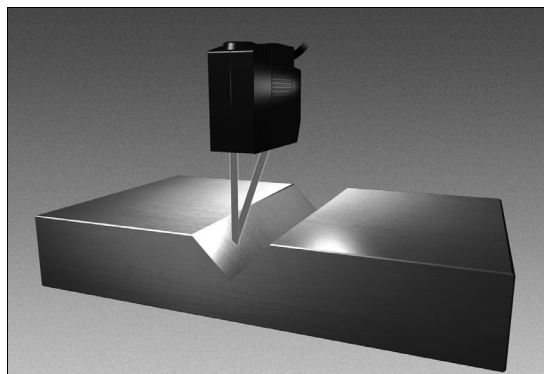

Measuring tire or black rubber thickness

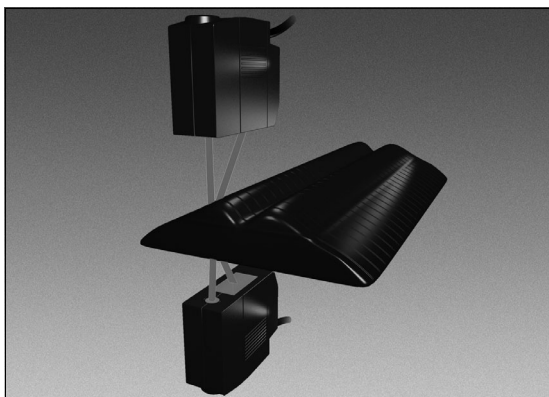

Grinding measurement of a whetstone

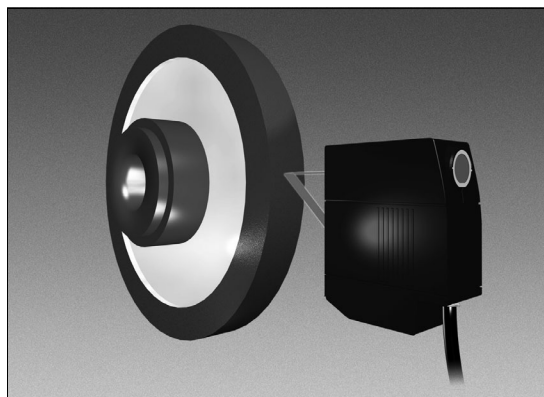

Z300

System configuration

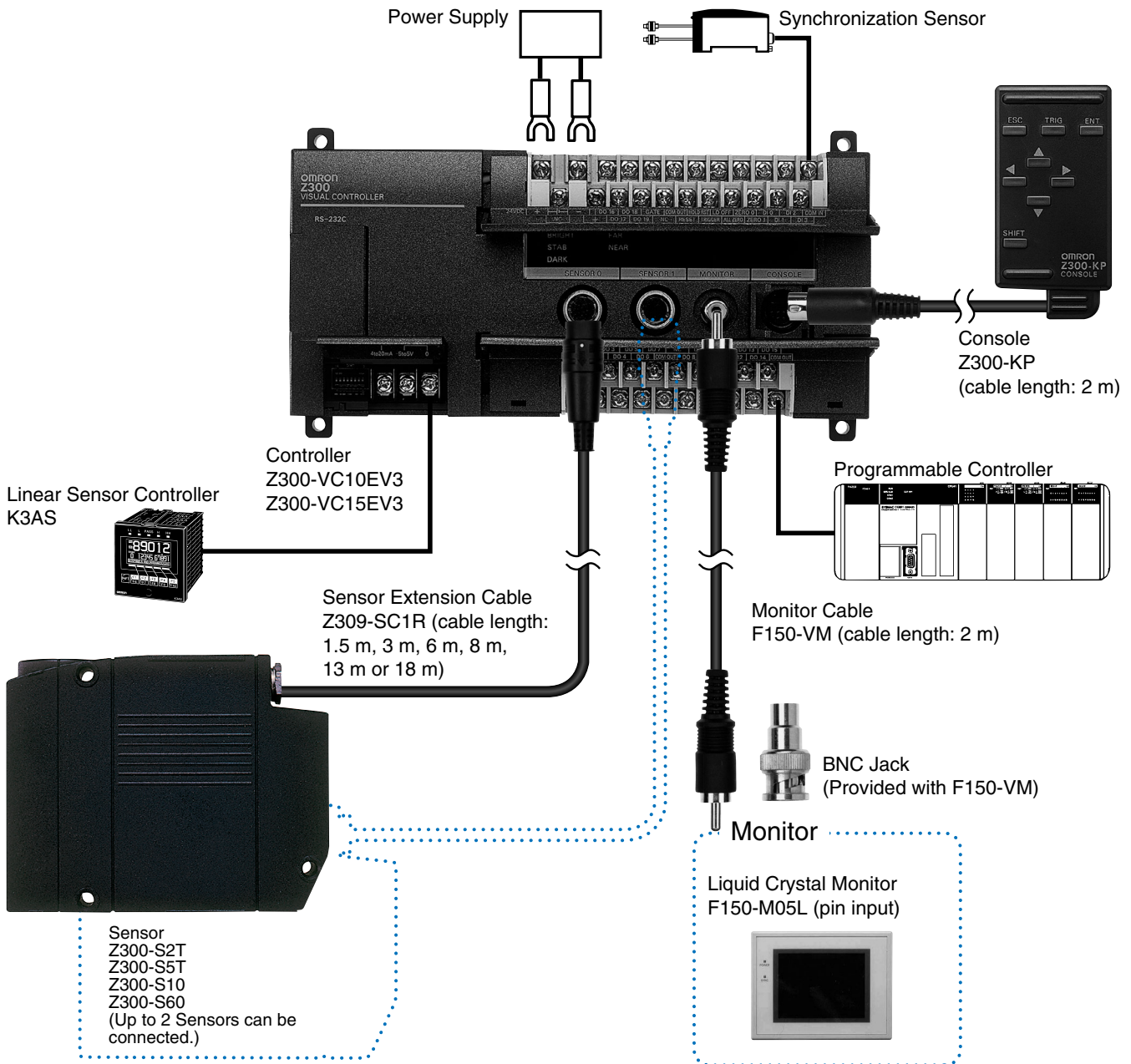

Ordering Information

| Name                   | Item | Model                | Remarks  |
|------------------------|------|----------------------|--|
| Sensor                 |      | Z300-S2T             |  |
|                        |      | Z300-S5T             |  |
|                        |      | Z300-S10             |  |
|                        |      | Z300-S60             |  |
| Controller             |      | Z300-VC10EV3         | NPN input/output                                 |
|                        |      | Z300-VC15EV3         | PNP input/output                                 |
| Console                |      | Z300-KP              |  |
| Liquid Crystal Monitor |      | F150-M05L            |  |
| Sensor Extension Cable |      | Z309-SC1R (See note) | Cable length: 1.5 m, 3 m, 6 m, 8 m, 13 m or 18 m |
| Monitor Cable          |      | F150-VM              |  |

Note: Specify the required cable length when ordering.

Rating/performance

Sensor: Z300-S2T/Z300-S5T/Z300-S10/Z300-S60

| Model                                     |                                | Z300-S2T   |   | Z300-S5T   |                   | Z300-S10  |                                     | Z300-S60   |
|---|--------------------------------|--|---|--|-------------------|---|-------------------------------------|--|
|   |                                | Diffuse reflection   | Mirror reflection                       | Diffuse reflection   | Mirror reflection | Diffuse reflection                                    | Mirror reflection                   | Diffuse reflection only  |
| Measurement mode                          |                                |  |   |  |                   |   |                                     |  |
| Distance to measurement center            |                                | ±5.2 mm  | 20 mm (with beam cover attached: 16 mm) | ±50 mm   | ±44 mm            | ±100 mm   | ±94 mm                              | ±600 mm  |
| Measurement range                         |                                | ±1 mm  |   | ±5 mm  | ±4 mm             | ±20 mm  | ±16 mm                              | ±350 mm (F.S. 700 mm)  |
| Light source                              |                                | Visible-light semiconductor laser (Wavelength: 650 nm, 1 mW max., Class 2)   |   | Visible-light semiconductor laser (Wavelength: 670 nm, 1 mW max., Class 2) |                   |   |                                     | Visible-light semiconductor laser (Wavelength: 658 nm, 15 mW max., Class 3B) |
| Beam dimensions (See note 1.)             |                                | 20 μm × 300 μm (200 μm*) TYP. (distance to measurement center)<br>* Measurement region   |   | 30 μm × 400 μm TYP. (distance to measurement center)                       |                   | 60 μm × 1000 μm TYP. (distance to measurement center) |                                     | 0.3 mm × 16 (10.3*) mm (at 500 mm)<br>* Measurement region                   |
| Linearity                                 |                                | ±0.05 %F.S. (See note 2.)  | ±0.05 %F.S. (See note 3.)               | ±0.1 %F.S. (See note 4.)   |                   |   |                                     | ±0.07 %F.S. (250 to 750 mm)<br>±0.1 %F.S. (750 to 950 mm) (See note 4.)      |
| Resolution                                |                                | 0.4 μm (See notes 5 and 6.)  |   | 0.4 μm (See notes 7 and 9.)  |                   | 1 μm (See notes 7 and 8.)                             |                                     | 8 μm (at 350 mm)<br>40 μm (at 600 mm) (See notes 7 and 8.)                   |
| Sampling period (See note 10.)            |                                | 540 μs   |   |  |                   |   |                                     |  |
| LED indicators                            | NEAR indicator                 | Lights if the workpiece is close to the measurement center or is on the near side of the measurement center and inside the measurement region.<br>Flashes if the workpiece is outside the measurement region or if the density is excessive or insufficient. |   |  |                   |   |                                     |  |
|   | FAR indicator                  | Lights if the workpiece is close to the measurement center or is on the far side of the measurement center and inside the measurement region.<br>Flashes if the workpiece is outside the measurement region or if the density is excessive or insufficient.  |   |  |                   |   |                                     |  |
| Temperature characteristic (See note 11.) |                                | ±0.01 %F.S./°C   |   |  |                   |   |                                     |  |
| Environment resistance                    | Degree of protection           | IEC IP64   |   | IEC IP67   |                   |   | IEC IP66                            |  |
|   | Ambient operating illumination | Illumination at light-receiving surface: 3,000 lx max., incandescent light   |   |  |                   |   |                                     |  |
|   | Ambient temperature            | Operating: 0 to +50 °C, Storage: -15 to +60 °C (with no icing or condensation)   |   |  |                   |   |                                     |  |
|   | Ambient humidity               | Operating and storage: 35 % to 85 % (with no condensation)   |   |  |                   |   |                                     |  |
| Vibration resistance                      |                                | 10 to 150 Hz (double amplitude: 0.35 mm) for 8 min. each in X, Y, and Z directions   |   |  |                   |   |                                     |  |
| Materials                                 |                                | Unit: Die-cast aluminum; Cable sheathing: Heat-resistant chlorinated vinyl<br>Connector: Zinc alloy and brass  |   |  |                   |   |                                     |  |
| Cable length                              |                                | 2 m  |   |  |                   |   |                                     | 50 cm  |
| Minimum bending radius                    |                                | 68 mm  |   |  |                   |   |                                     |  |
| Weight                                    |                                | Approx. 600 g (Unit: Approx. 350 g)  |   | Approx. 800 g (Unit: Approx. 600 g)  |                   |   | Approx. 800 g (Unit: Approx. 700 g) |  |
| Accessories                               |                                | 3 ferrite cores, laser warning labels (English)  |   |  |                   |   |                                     |  |

Note: 1. Defined at 1/e<sup>2</sup> (13.5 %) of the density at the light center. Light may, however, be present outside this range and if the reflection factor of the light around the workpiece is high compared to the workpiece, measurement may be affected.  
2. Error with respect to the theoretical line representing the displacement output for measurement of OMRON standard SUS blocks. The linearity varies with the type of workpiece.

- 3. Error with respect to the theoretical line representing the displacement output for measurement of OMRON standard quartz glass. The linearity varies with the type of workpiece.
- 4. Error with respect to the theoretical line representing the displacement output for measurement of OMRON standard white alumina ceramics. The linearity varies with the type of workpiece.

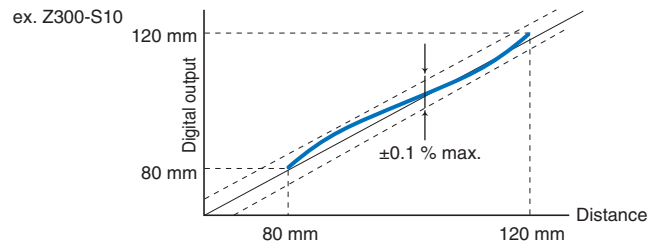

- 5. Displacement conversion value for peak-to-peak of displacement output. These figures are for measurement of OMRON standard quartz glass (mirror reflection mode) or OMRON standard SUS blocks (diffuse reflection) at the measurement center.  
In magnetic fields, it may not be possible to maintain resolution performance characteristics.
- 6. These figures are for when the Sensor is connected to the Z300-VC10EV3/VC15EV3, the average number of measurements is 256, and M command RS-232C output is used.
- 7. Displacement conversion value for peak-to-peak of displacement output (for measurement of OMRON standard white alumina ceramic at the measurement center).  
In strong magnetic fields, it may not be possible to maintain resolution performance characteristics.
- 8. With the Z300-VC10EV3/VC15EV3, at an average number of measurements of 64.
- 9. With the Z300-VC10EV3/VC15EV3, at an average number of measurements of 512.
- 10. Value for measurement with 1 line (high speed) set in CCD Mode.
- 11. Value for measurement with the space between the Sensor and the workpiece (Z300-S5T/S10/S60: white alumina ceramic; Z300-S2T: quartz glass) secured with an aluminum jig.



Controller: Z300-VC10EV3/Z300-VC15EV3

| Item                       | mode   | VISUAL mode   | NON-VISUAL mode  |
|----------------------------|--|---|--|
| Performance specifications | Number of Sensors that can be mounted  | 2   | 1  |
|                            | Number of scenes   | 16  | 1  |
|                            | Image memory function  | NG images: 20 scenes max.; Surrounding images: 4 scenes max.; Workpiece display images: 4 scenes max.   | —  |
|                            | Processing method  | Gray center of gravity, edge centering  | Edge centering   |
|                            | Pre-image processing   | Noise removal, smoothing  | None   |
|                            | Averaging/filtering  | Average number of times (12 stages, 1 to 4096 times), HPF (high pass filter)  | Average number of times (SLOW: 64 times; FAST: 1 time)   |
|                            | Light intensity tracking function  | Automatic (The light intensity tracking range can be specified.)<br>Fixed (Select from 32 stages.)  | Automatic (The light intensity tracking range can not be specified.)<br>Fixed (Select either HIGH or LOW.) |
|                            | Applications   | Select from the following 8 types:<br>Surface displacement, spot displacement, maximum height, groove/indentation, level difference, transparent workpiece thickness, level difference (2 Sensors), or thickness (2 Sensors).   | —  |
|                            | Region specification   | Region specification of line beam and displacement direction is possible.   | —  |
|                            | Two region measurement modes   | Absolute coordinate mode and relative coordinate mode   | —  |
|                            | Hold functions   | Sampling, peak, bottom, peak-to-peak, average, and length   | —  |
|                            | Two Sensor measurement modes   | Simultaneous measurement and alternate measurement  | —  |
|                            | Measurement data   | 4 outputs per scene   | 1 output   |
|                            | Equations  | The following operations are possible for outputs 0 to 3:<br>K+A, K-A, K+(A+B), K-(A-B), and K-(A+B)<br>A and B: Specified measurement points<br>K: Freed constant  | —  |
|                            | Results output   | Judgement output (HIGH, PASS, LOW, ERROR)<br><ul style="list-style-type: none"> <li>→ RS-232C output</li> <li>→ Terminal block output</li> </ul> Measurement value output (measurement value)<br><ul style="list-style-type: none"> <li>→ RS-232C output</li> <li>→ Terminal block output</li> <li>→ Analog output</li> </ul> | Analog output  |
|                            | Terminal block   | 11 input points: <u>TRIGGER</u> , <u>HOLD-RESET</u> , <u>LD-OFF</u> , <u>ALL-ZERO</u> , <u>ZERO0</u> , <u>ZERO1</u> , <u>RESET</u> , and DI 0 to DI 3<br>21 output points: DO0 to DO20  | <u>LD-OFF</u>  |
| Input/Output Type          | Z300-VC10EV3: NPN<br>Z300-VC15EV3: PNP   |   |  |
| Monitor interface          | 1 channel (for pin jack or overscan monitor)   | —   |  |
| Analog output resolution   | The full scale for output can be divided into a maximum of 40000 gradations.<br>Resolution (See note.) * 0.25 mV (±5 V), 0.4 μA (4 to 20 mA) |   |  |

Note: For measurement at an average number of times of 64 with an OMRON K3AS Linear Sensor Controller connected.

| Item                   | mode                                 | VISUAL mode   | NON-VISUAL mode |
|------------------------|--------------------------------------|---|-----------------|
| General specifications | Supply voltage                       | 21.6 to 26.4 VDC (including ripple)   |                 |
|                        | Current consumption                  | 1 A max. (with 2 Sensors connected)   |                 |
|                        | Insulation resistance                | 20 MΩ min. between all DC external terminals and GR terminal (100 VDC Megger, with internal surge absorber removed) |                 |
|                        | Dielectric strength                  | 1000 VAC, 50/60 Hz between all DC external terminals and GR terminal (with internal surge absorber removed)         |                 |
|                        | Leakage current                      | 10 mA max.  |                 |
|                        | Noise resistance                     | 1500 Vp-p; Pulse width: 0.1 μs/ 1 μs; Rising edge: 1-ns pulse   |                 |
|                        | Vibration resistance                 | 10 to 150 Hz (double amplitude: 0.1 mm) for 8 min. each in X, Y, and Z directions                                   |                 |
|                        | Shock resistance                     | 200 m/s <sup>2</sup> , 3 times each in 6 directions   |                 |
|                        | Ambient temperature                  | Operating: 0 to +50 °C, Storage: -15 to +60 °C (with no icing or condensation)                                      |                 |
|                        | Ambient humidity                     | Operating and storage: 35 % to 85 % (with no condensation)  |                 |
|                        | Ambient environment                  | No corrosive gases  |                 |
|                        | Ground                               | Ground the Z300's ground terminal to less than 100 Ω  |                 |
|                        | Degree of protection                 | IEC60529 IP20 (in-panel)  |                 |
|                        | Case material                        | Controller: ABS   |                 |
|                        | Weight (including packaging)         | Approx. 1300 g (Unit: Approx. 700 g)  |                 |
| Accessories            | 2 manuals, 1 resistor (250 Ω, 1/2 W) |   |                 |

Monitor

| Item                         | Monitor Model | Liquid Crystal Monitor   |
|------------------------------|---------------|--|
|                              |               | F150-M05L  |
| Size                         |               | 5.5 inches   |
| Type                         |               | TFT color liquid crystal   |
| Resolution                   |               | 320 × 240 dots   |
| Input signal                 |               | NTSC composite video (1.0 V / 75 Ω)  |
| Supply voltage               |               | 20.4 to 26.4 VDC   |
| Current consumption          |               | Approx. 700 mA   |
| Ambient temperature          |               | Operating: 0 °C to +50 °C, Storage: -25 °C to +65 °C (with no icing or condensation) |
| Ambient humidity             |               | Operating and storage: 35 to 85 %RH (with no condensation)                           |
| Weight (including packaging) |               | Approx. 870 g (Unit: Approx. 610 g)  |
| Accessories                  |               | Operation manual, 4 mounting brackets  |

## Laser Safety

The Z300-S2T, Z300-Z5T and Z300-S10 Sensor Heads are Class 2 Laser Products according to EN60825-1 (IEC60825-1) and Class II Laser Product according to FDA (21 CFR1040.10) (see note). The Z300-S60 Sensor Head is a Class 3B and Class IIIB Laser Product, respectively. The Z300 Series is meant to be built into final system equipment. Pay special attention to the following precautions for the safe use of the product:

Note: Europe: Class 2 and Class 3B of EN60825-1: 1994 = IEC60825-1: 1993  
 U.S.A.: Class II and Class IIIB of FDA (21 CFR1040.10)

|                        | Z300-S2T     | Z300-S5T | Z300-S10 | Z300-S60     |
|------------------------|--------------|----------|----------|--------------|
| Wavelength             | 650 nm       | 670 nm   |          | 658 nm       |
| Peak power             | 1 mW max.    |          |          | 15 mW max.   |
| Class                  | 2            |          |          | 3B           |
| Maximum pulse duration | 7 ms         |          |          | 17.5 ms      |
| Period                 | 0.5 to 10 ms |          |          | 0.5 to 25 ms |

- (1) Use this product as specified in the operation manual. Otherwise, you may be exposed to hazardous laser radiation.
- (2) The Z300 series radiates laser beams in the visible light range. Do not expose your eyes directly to the laser radiation. Ensure that the laser beam path is terminated during use. If a mirror or shiny surface is positioned in the laser beam path, ensure that the reflected beam path is also terminated.  
 If the Unit must be used without terminating the laser beam path, position the laser beam path so that it is not at eye level.
- (3) To avoid exposure to hazardous laser radiation, do not displace nor remove the protective housing during operation, maintenance, and any other servicing.
- (4) The user should return the product to OMRON for all repair and servicing.
- (5) As for countries other than those of Europe and the U.S.A., observe the regulations and standards specified by each country.

## Precautions

### Warming up

After turning on the power, wait about 30 minutes before using the equipment. The circuits are not stable after turning on the power, and thus measured values tend to gradually drift.

Dimensions (Unit: mm)

Sensor

Z300-S2T

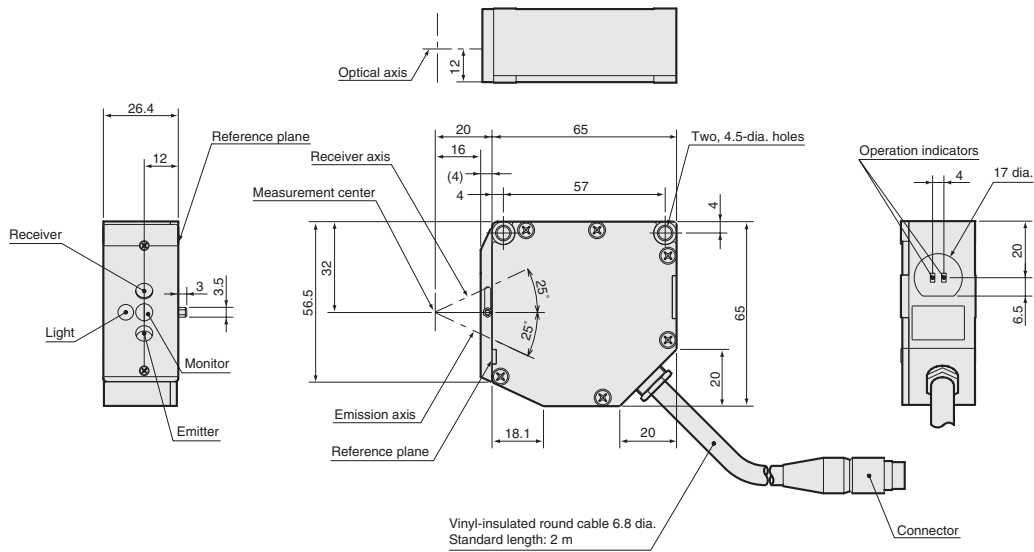

Z300-S5T

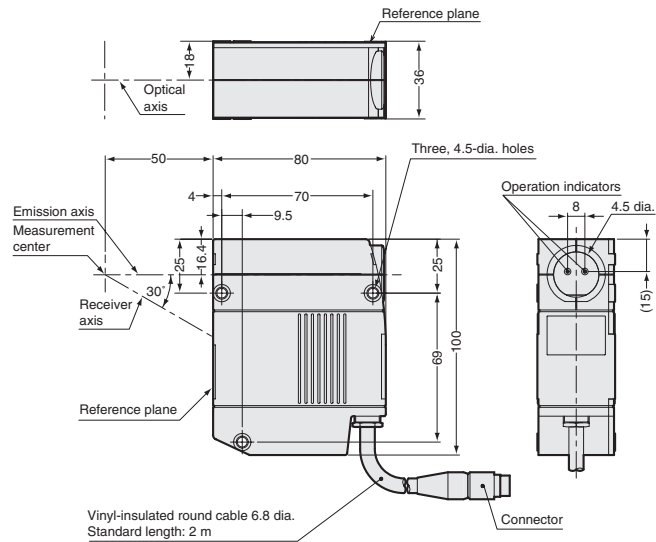

Z300-S10

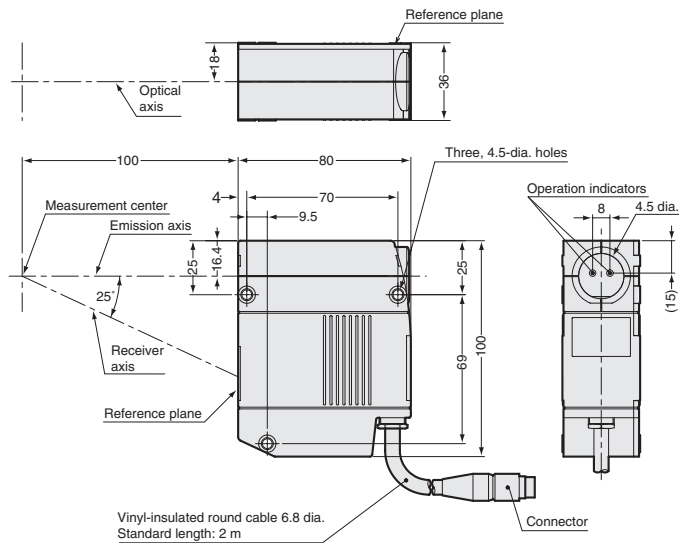

Z300-S60

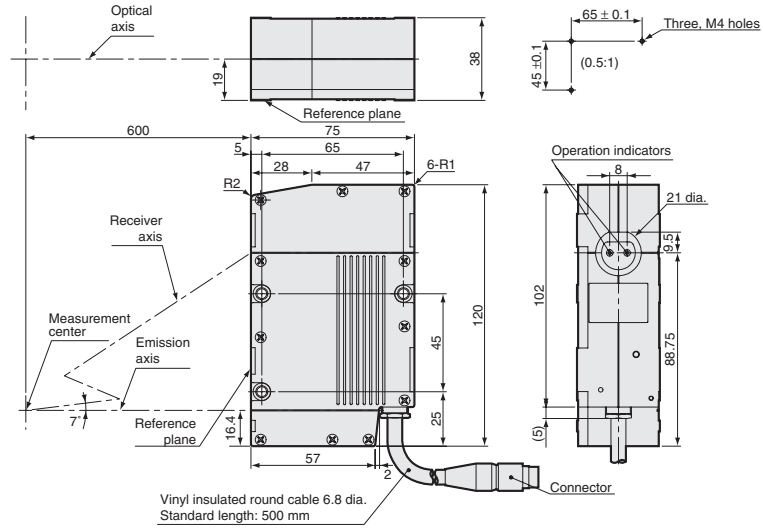

Controller

Z300-VC10EV3  
Z300-VC15EV3

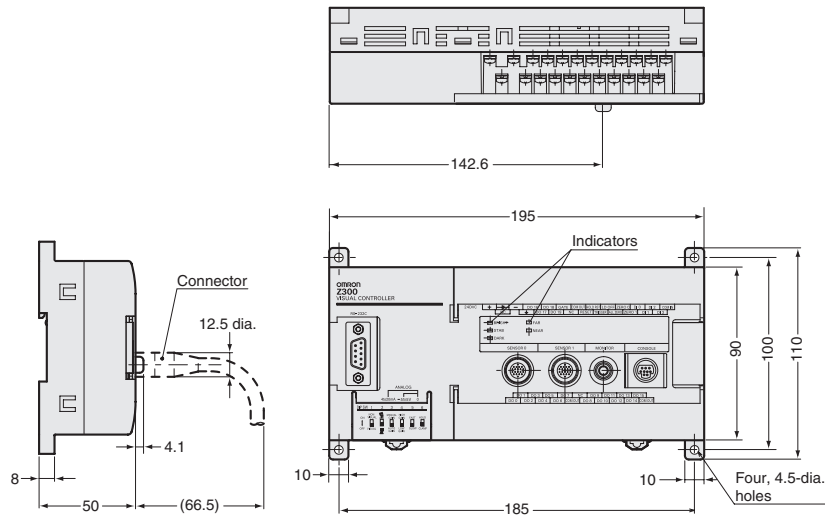

Console

Z300-KP

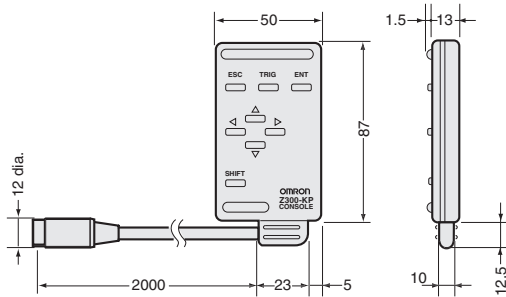

LCD monitor

F150-M05L

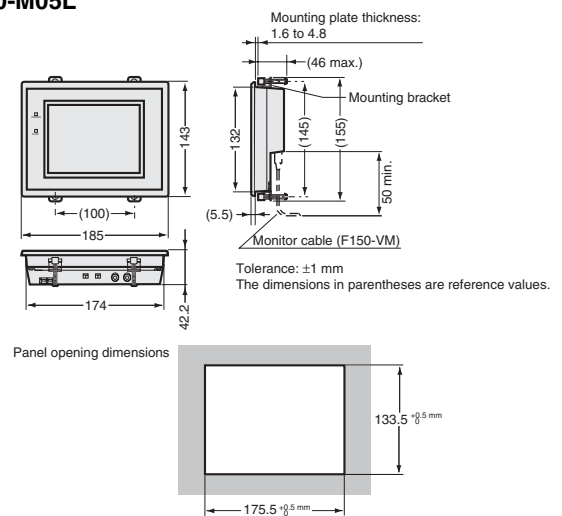

ALL DIMENSIONS SHOWN ARE IN MILLIMETERS.

To convert millimeters into inches, multiply by 0.03937. To convert grams into ounces, multiply by 0.03527.