

Switching Power Supply S82S

Miniature DIN-rail Mounting DC-DC

- Power Supplies
- 3 W and 7.5 W models.
- Inputs: 10 to 27 VDC (DC input)
- Outputs: 5, 12, 15, 24, ± 12 , and ± 15 V.
- 65 mm depth enables mounting onto panels with 100 mm depth.



Ordering Information

Power ratings	Output voltage	Output current	Model
3 W	5 V	0.6 A	S82S-7305
	12 V	0.25 A	S82S-7312
	15 V	0.2 A	S82S-7315
	24 V	0.13 A	S82S-7324
7.5 W	5 V	1.5 A	S82S-7705
	12 V	0.6 A	S82S-7712
	15 V	0.5 A	S82S-7715
	24 V	0.3 A	S82S-7724
	± 12 V	0.3 A (+12 V) / 0.2 A (-12 V)	S82S-7727
	± 15 V	0.2 A (+15 V) / 0.2 A (-15 V)	S82S-7728

Model Number Structure

■ Model Number Legend.

S82S-

1 2 3

1. Power Ratings

07: 12 to 24 VDC

2. Output voltage

03: 3 W

07: 7.5 W

3. Configuration/function

05: 5 V

12: 12 V

15: 15 V

24: 24 V

27: ± 12 V

28: ± 15 V

Specifications

■ Ratings/Characteristics

Item		DC input		
		3 W	Single output 7.5 W	Dual output 7.5 W
Efficiency (typical)		60% to 73% (Varies with specifications.)		
Life expectancy		8 yrs. min. (Used at 40°C at the rated input with a 50% load.)		
Input	Voltage	10.2 to 27.6 VDC		
	Current (with rated I/O)	0.6 A max.	1.2 A max.	
	Noise filter	Yes		
Output	Voltage adjustment range	±5%	±5%	Not possible (See note 1)
	Ripple	2% (p-p) max		
	Input variation influence	0.5% max. (10.2 to 27.6 VDC input, 100% load)		
	Load variation influence	1.5% max.	1.5% max.	+V: 1.5% max. -V: 3% max.
	Temperature variation influence	0.05%/°C max.		
Additional function	Overload protection	105% min. of rated load current (typical), drop type, automatic reset		
Other	Ambient temperature	Operating: See the derating curve in the "Engineering Data" section Storage: -25°C to 65°C		
	Ambient humidity	Operating: 25% to 85% Storage: 20% to 90%		
	Dielectric strength	1,500 VAC, 50/60Hz for 1 min (between all inputs and outputs/GR terminal)		
	Insulation resistance	100 MW min. at 500 VDC (between all outputs and inputs/GR terminal)		
	Vibration resistance	Malfunction: 10 to 55 Hz, 0.375-mm single amplitude each in X, Y, and Z directions for 2 hours.		
	Shock resistance	Malfunction: 294 m/s ² , 3 times each in ±X, ±Y, and ±Z directions		
	Screw tightening torque	0.74 N.m max. (See note 2)		
	Output indicator	Yes (green)		
	Approved standards	UL 508, CSA E.B.1402C		
Weight	150 g max.			

Note: 1. The settings for the output voltage must be within the following range:

+V: ±1% of the rated value

-V: ±5% of the rated value

2. Do not press down on the terminal block with a force exceeding 75 N while tightening the terminals.

Engineering Data

Derating Curve

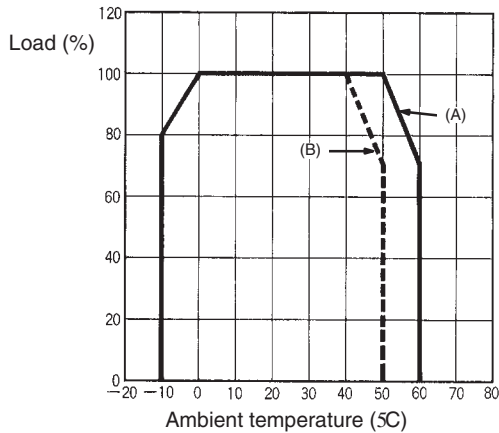

Note: The derating curve depends on the mounting direction of the Power Supply

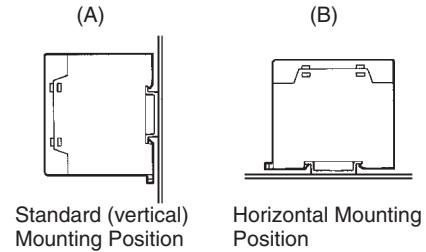

Overload Protection

The power supply is provided with an overload protection function that protects the load and the power supply from possible damage by overcurrent. When the output current rises above a set value (105% of the rated output current), the protection function is triggered, decreasing the output voltage. When the output current falls within the rated range, the overload protection function is automatically cleared.

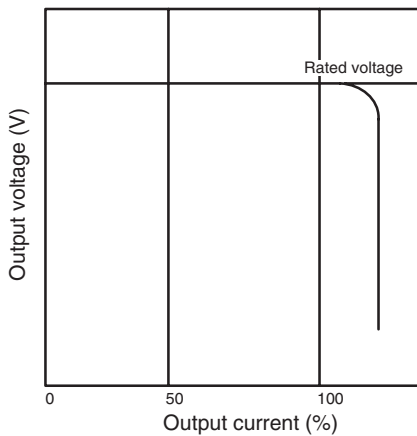

Inrush Current, Startup Time, Hold Time

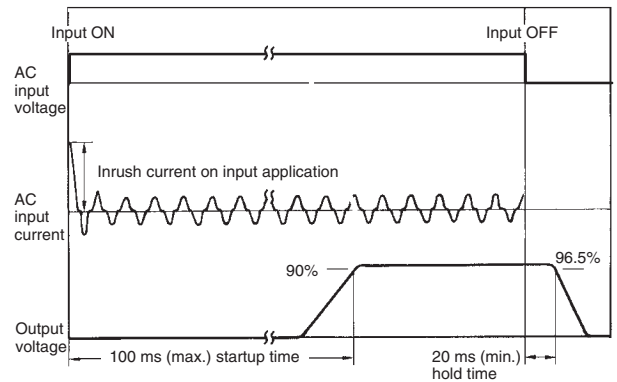

Dual Output Models

+V output is provided with an overload protection that protects the load and the power supply by detecting total load value of +V and -V output. It operates at 105% min. of the rated current of +V output when -V output is producing the rated output, but this condition varies depending on -V output status. -V output has an independent short-circuit protection feature.

Operation

■ Single Output

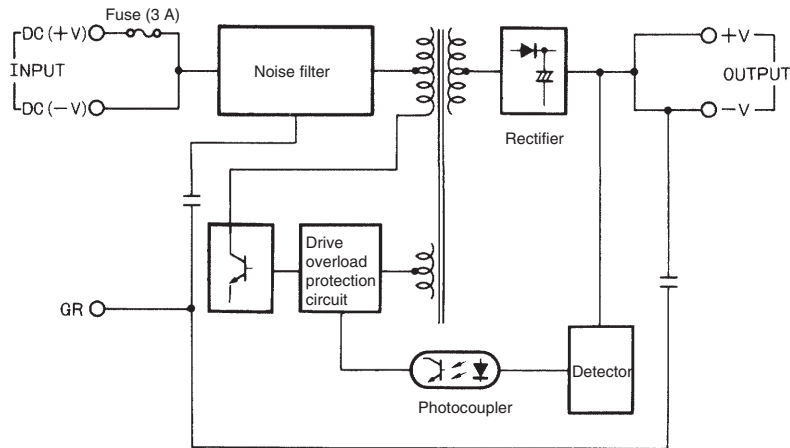

■ Dual Outputs

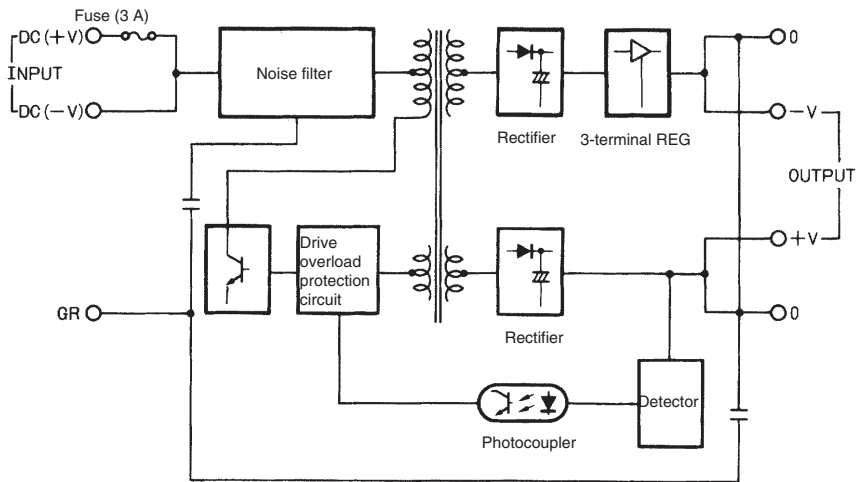

Dimensions

Note: All units are in millimeters unless otherwise indicated.

S82S-73□□ (3 W)
S82S-77□□ (7.5 W)

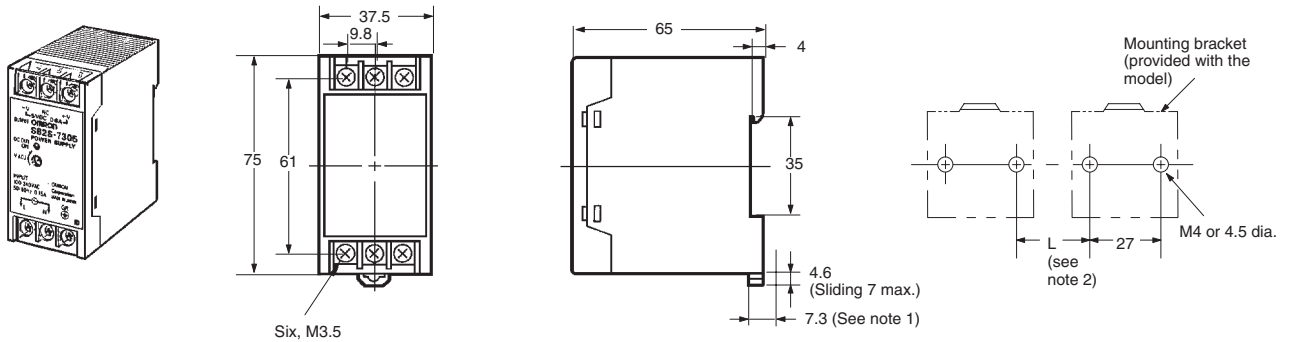

- Note:**
1. A distance of 7.3 mm is required between the model and the mounting surface when the mounting bracket provided with the model is used.
 2. If more than one Power Supply is installed in a row, keep a distance of 20 mm min. (L = 20 mm min.) between each adjacent Power Supply.

Installation

Terminal Arrangement

Single Output Models

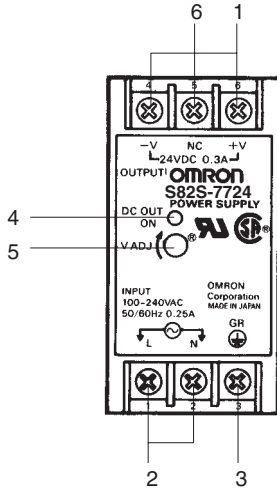

Dual Output Models

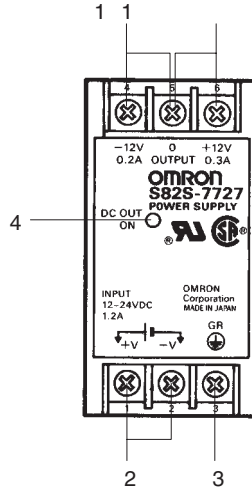

1. **DC Output Terminals:** Connect the load lines to these terminals.
 2. **Input Terminals:** Connect the input lines to these terminals.
- Note:** A fuse is inserted to side +V.
3. **Ground Terminal:** Connect a ground line to this terminal.
 4. **Output LED Indicator:** Lights while a DC output is ON (for the Dual Output Models, this indicator is lit when the +V DC output is ON).
 5. **V.ADJ Adjuster:** Adjusts the output voltage.
 6. **NC Terminals:** Vacant terminals.

Precautions

■ Mounting

To improve and maintain the reliability of the power supply over a long period of time, adequate consideration must be given to heat radiation.

The power supply is designed to radiate heat by means of natural air-flow. Therefore, mount the power supply so that air flow takes place around the power supply.

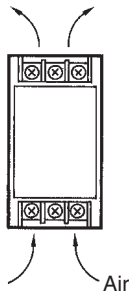

When mounting two or more power supplies side-by-side, allow at least 10 mm spacing between them, as shown in the following diagram.

Forced air-cooling is recommended.

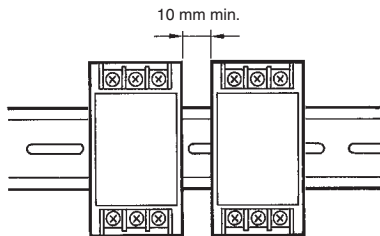

To mount the power supply on a track, hook portion (A) of the power supply to the track and press the power supply to fit in portion (B).

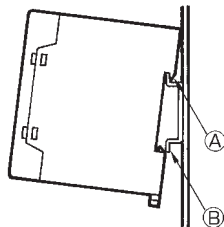

To dismount, pull down portion (C) with a screwdriver and pull out the power supply.

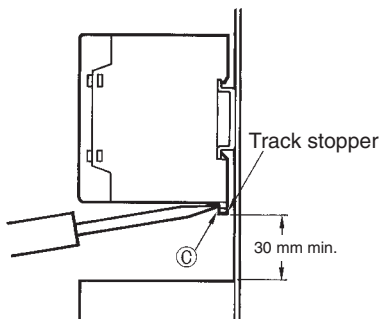

Generating Output Voltage (\pm)

An output of \pm can be generated by using two power supplies as shown, because the power supply produces a floating output.

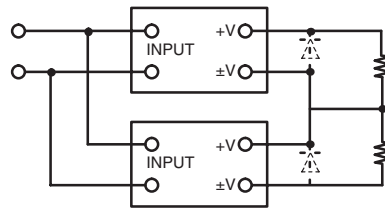

When connecting the power supplies in series with an operation amplifier, connect diodes to the output terminals (as shown by the dotted lines in the figure). Contact your OMRON representative for details on connecting diodes.

Serial or Parallel Operation

No serial or parallel operation is available.

The positive and negative output terminals of a Dual Output Model cannot be connected in series to operate.

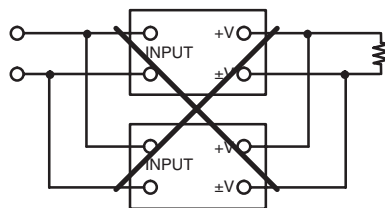
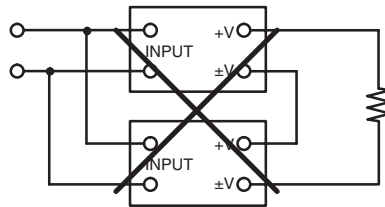

Input Terminals

Do not connect the input line to the other terminals of the power supply or the power supply will be damaged. The input terminals of DC input models have polarity. If the input polarities are reversed, the power supply will be damaged.

Minimum Output Current

The minimum output current of the S82S-7727 and S82S-7728 is restricted by the output voltage and control method.

Note: All the outputs of the S82S-7727 and S82S-7728 are controlled by the +V output. If the +V output current falls to 10% or less of the rated output, the -V output voltage may drop.

ALL DIMENSIONS SHOWN ARE IN MILLIMETERS.
To convert millimeters into inches, multiply by 0.03937. To convert grams into ounces, multiply by 0.03527.