

LETLA-□-F□

# Sigma linear axis

## Linear servo axis ready to use

- Highly enclosed construction avoids falling parts into the magnets and bearings area
- Plug and drive, shorten start-up time
- Long durability, reliable and constant performance after years of use
- Designed for an easy servicing
- Direct control of the axis using XtraDrive and Sigma-II drives
- Extremely energy efficient, due to its optimised magnetic circuitry design and high-density winding
- For special lengths, special specifications and XY systems contact your OMRON sales office



## Ratings

- 230 VAC Single-phase 80 to 560 N (1200 N peak)
- 400 VAC Three-phase 80 to 1200 N (2400 N peak)

## System configuration

(Refer to Servo Drive chapter)

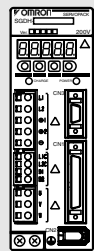

**Servo Drive with option boards for flexible system configuration**

Sigma-II Servo Drive

Drive options

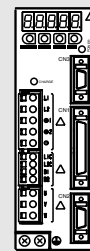

**Intelligent Servo Drive**

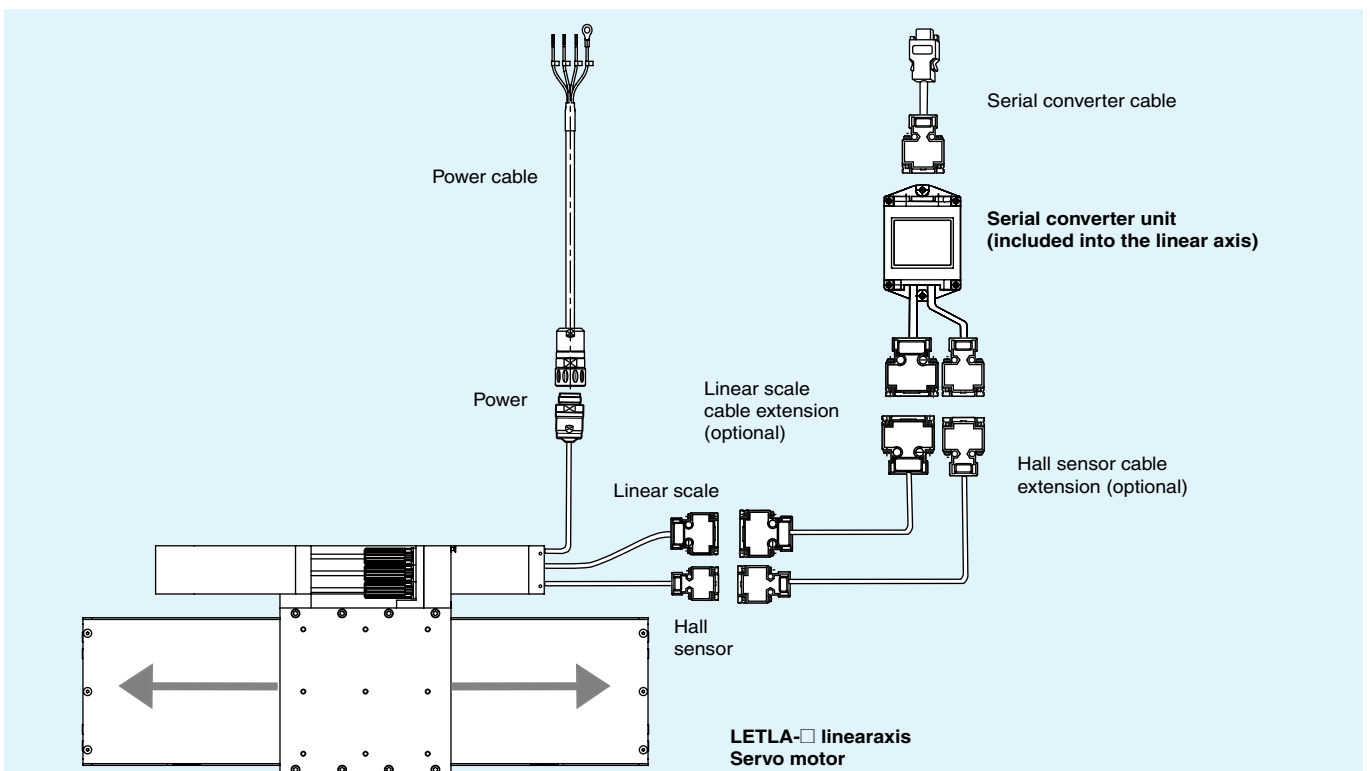

Sigma series linear axis					Serial converter (included in LETLA)	Servo drive			
Type	Voltage	Rated force	Peak force	Model	Model JZDP-□008-	Sigma-II series			
						230 V (1-phase)	400 V (3-phase)	230 V (1-phase)	400 V (3-phase)
LETLA-□- Linear motor axes	230 V	80 N	220 N	LETLA-□-F35A120-□	019	SGDH-02AE-OY	-	XD-02-MN01	-
		160 N	440 N	LETLA-□-F35A230-□	020	SGDH-08AE-S-OY	-	XD-08-MN	-
		280 N	600 N	LETLA-□-F50A200-□	181	SGDH-08AE-S-OY	-	XD-08-MN	-
		560 N	1200 N	LETLA-□-F50A380-□	182	SGDH-15AE-S-OY	-	XD-15-MN	-
		560 N	1200 N	LETLA-□-F1ZA200-□	183	SGDH-15AE-S-OY	-	XD-15-MN	-
		560 N	1200 N	LETLA-□-F1ZA200-□	183	SGDH-15AE-S-OY	-	XD-15-MN	-
	400 V	80 N	220 N	LETLA-□-F35D120-□	211	-	SGDH-05DE-OY	-	XD-05-TN
		160 N	440 N	LETLA-□-F35D230-□	212	-	SGDH-05DE-OY	-	XD-05-TN
		280 N	600 N	LETLA-□-F50D200-□	189	-	SGDH-10DE-OY	-	XD-10-TN
		560 N	1200 N	LETLA-□-F50D380-□	190	-	SGDH-15DE-OY	-	XD-15-TN
		560 N	1200 N	LETLA-□-F1ZD200-□	191	-	SGDH-15DE-OY	-	XD-15-TN
		560 N	1200 N	LETLA-□-F1ZD200-□	191	-	SGDH-15DE-OY	-	XD-15-TN
		1120 N	2400 N	LETLA-□-F1ZD380-□	192	-	SGDH-30DE-OY	-	XD-30-TN
		1120 N	2400 N	LETLA-□-F1ZD380-□	192	-	SGDH-30DE-OY	-	XD-30-TN

Type designation

Linear axis

LETLA - C - F50 A 200 - 0549 - NA0020 - D C

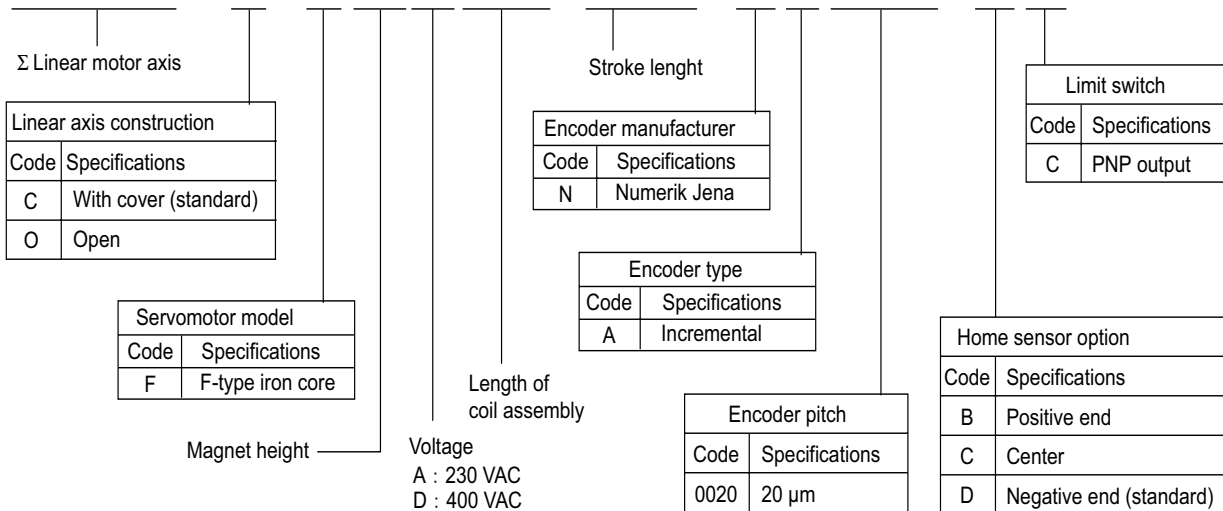

Servomotor specifications

Linear axis LETLA-□-F□□A (200 V)

Voltage		230V						
Linear axis model		LETLA-□-	F35A120-□-NA0020	F35A230-□-NA0020	F50A200□-NA0020	F50A380□-NA0020	F1ZA200□-NA0020	
Motor coil specifications	Linear servo motor coil used	SGLFW-	35A120A	35A230A	50A200B	50A380B	1ZA200B	
	Rated force*1	N	80	160	280	560	560	
	Instantaneous peak force*1	N	220	440	600	1200	1200	
	Rated current*1	Arms	1.4	2.8	5.0	10.0	8.7	
	Instantaneous peak current*1	Arms	4.4	8.8	12.4	25.0	21.6	
	Force constant	N / Arms	62.4	62.4	60.2	60.2	69.0	
	BEMF constant	V / (m / s)	20.8	20.8	20.1	20.1	23.0	
	Motor constant	N / √w	14.4	20.4	34.3	48.5	52.4	
	Electrical time constant	ms	3.6	3.6	15.9	15.8	18.3	
	Mechanical time constant	ms	6.2	5.5	3.0	2.9	2.3	
Axis specifications	Position accuracy repeatability*2	µm						+/-1
	Absolute position accuracy*2	µm/100mm						+/-5
	Linear encoder resolution	µm						0.078µm = 20µm / 256 (8bit)
	Static friction of the axis*3	N	20	25	30	35	50	
	Maximum load*3	kg	60	60	80	80	150	
	Bearings model used	THK	SSR 15	SSR 15	SSR 15	SSR 15	SSR 25	
	Linear measuring head used	Numerik Jena						LIA20-C001-KZ
Linear measuring scale used							MV5340□□□□	
Available lengths	m	Standard length up to 2.5 m (see dimensions section) / for lengths up to 5 m contact your OMRON sales office						
Basic specifications	Time rating	Continuous						
	Insulation class	Class B						
	Ambient temperature	0 to +40 °C						
	Ambient humidity	20 to 80% (non-condensing)						
	Insulation resistance	500 VDC, 10 MΩ min.						
	Excitation	Permanent magnet						
	Dielectric strength	1500 VAC for 1 minute						
	Protection methods	Self-cooled						
	Allowable winding temperature	130 °C						

Note: \*1. The items marked with an \*1 and "Force and speed characteristics" are the values at a motor winding temperature of 100 °C during operation in combination with a servo drive. The others are at 20 °C (68°F).

\*2. With stable environmental conditions and motor temperature unchanged.

\*3. Items calculated with load position like in figure below.

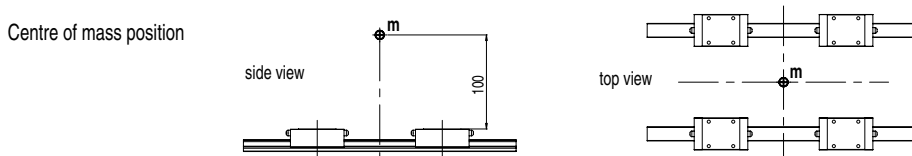

Force-speed characteristics (200 V)

A: Continuous duty zone B: Intermittent duty zone

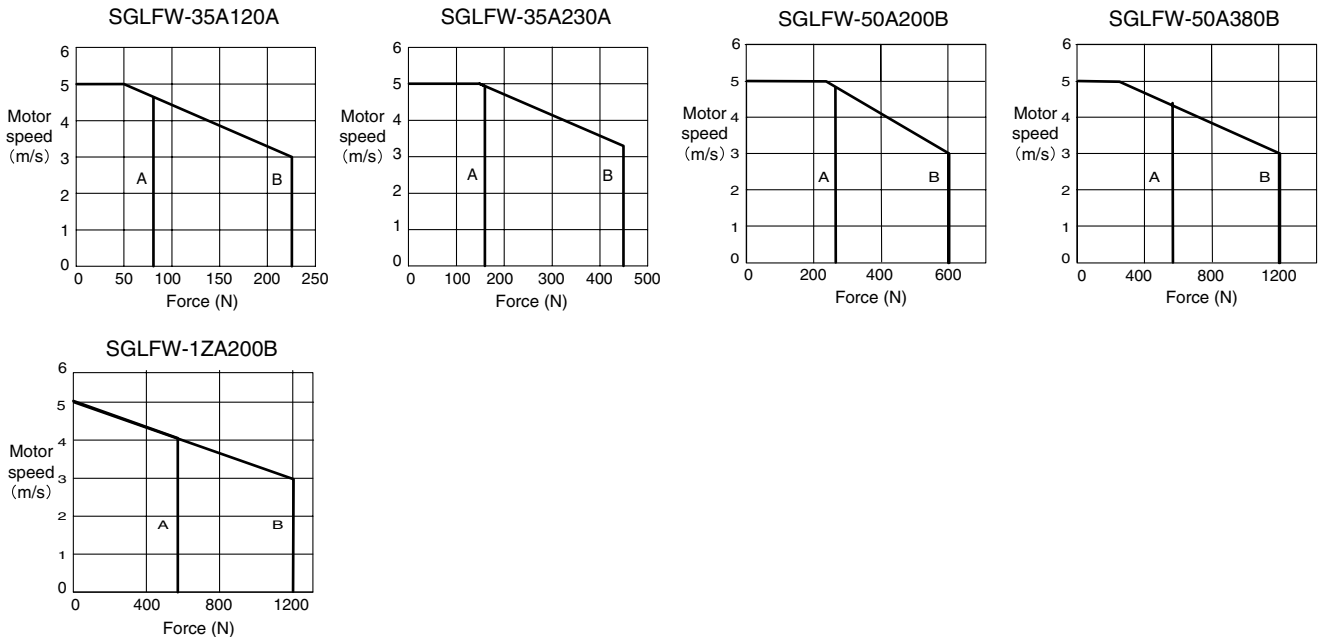

Linear axis LETLA-□-F□□□D(400V)

Voltage		400V						
Linear axis model		LETLA-□-	F35D120-□-NA0020	F35D230-□-NA0020	F50D200-□-NA0020	F50D380-□-NA0020	F1ZD200-□-NA0020	F1ZD380-□-NA0020
Motor coil specifications	Linear Servomotor coil used	SGLFW-	35D120A	35D230A	50D200B	50D380B	1ZD200B	1ZD380B
	Rated force*1	N	80	160	280	560	560	1120
	Instantaneous peak force*1	N	220	440	600	1200	1200	2400
	Rated current*1	$A_{rms}$	0.7	1.4	2.3	4.5	4.9	9.8
	Instantaneous peak current*1	$A_{rms}$	2.3	4.6	5.6	11.0	12.3	24.6
	Force constant	$N / A_{rms}$	120.2	120.2	134.7	134.7	122.6	122.6
	BEMF constant	$V / (m / s)$	40.1	40.1	44.9	44.9	40.9	40.9
	Motor constant	$N / \sqrt{w}$	13.8	19.5	33.4	47.2	51.0	72.1
	Electrical time constant	ms	3.5	3.5	15.0	15.0	17.4	17.2
	Mechanical time constant	ms	5.5	5.5	3.2	3.2	2.5	2.2
	Axis specifications	Position accuracy repeatability*2	$\mu m$	+/-1				
Absolute position accuracy*2		$\mu m/100mm$	+/-5					
Linear encoder resolution		$\mu m$	0.078 $\mu m = 20 \mu m / 256$ (8 bit)					
Static friction of the axis*3		N	20	25	30	35	50	60
Maximum load*3		kg	60	60	80	80	150	150
Bearings model used		THK	SSR 15	SSR 15	SSR 15	SSR 15	SSR 25	SSR 25
Linear measuring head used		Numerik Jena	LIA20-C001-KZ					
Linear measuring scale used		MV5340□□□□						
Available lengths	m	Standard length up to 2.5 m (see dimensions section) / for lengths up to 5m contact you OMRON sales office						
Basic specifications	Time rating	Continuous						
	Insulation class	Class B						
	Ambient temperature	0 to +40° C						
	Ambient humidity	20 to 80% (non-condensing)						
	Insulation resistance	500 VDC, 10 M $\Omega$ min.						
	Excitation	Permanent magnet						
	Dielectric strength	1500 VAC for 1 minute						
	Protection methods	Self-cooled						
	Allowable winding temperature	130 °C						

**Note:** \*1. The items marked with an \*1 and "Force and speed characteristics" are the values at a motor winding temperature of 100 °C during operation in combination with a servo drive. The others are at 20 °C (68°F)

\*2. With stable environmental conditions and motor temperature unchanged

\*3. Items calculated with load position like in figure below

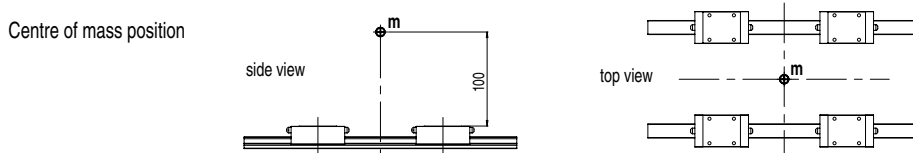

Force-speed characteristics (400 V)

A: Continuous duty zone B: Intermittent duty zone

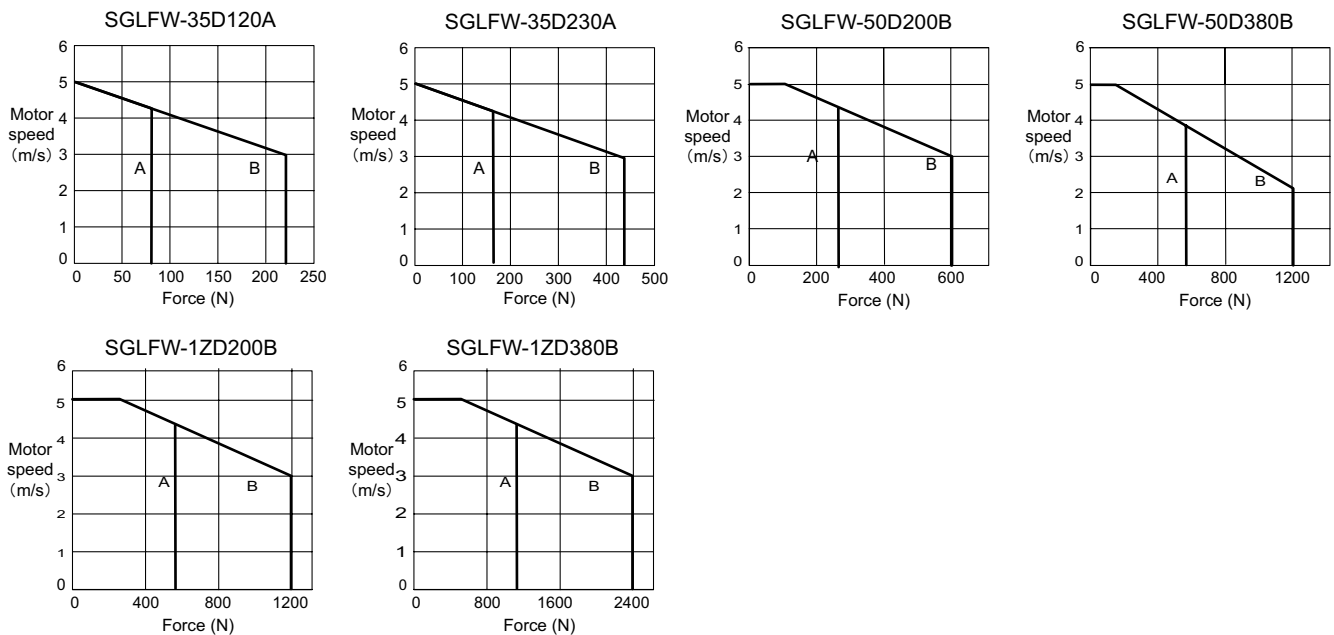

Dimensions

LETLA-C-F35□120-□

Linear axis model	Effective stroke in mm	L1 in mm	L2 in mm	Weight of moving table including motor coil (kg)	Weight of the complete axis (kg)
LETLA-C-F35□120-0103-NA0020-□□	103	403	29.5	7.6	16
LETLA-C-F35□120-0319-NA0020-□□	319	619	17.5	7.6	19
LETLA-C-F35□120-0427-NA0020-□□	427	727	31.5	7.6	21
LETLA-C-F35□120-0535-NA0020-□□	535	835	45.5	7.6	23
LETLA-C-F35□120-0643-NA0020-□□	643	943	19.5	7.6	25
LETLA-C-F35□120-0751-NA0020-□□	751	1051	33.5	7.6	27
LETLA-C-F35□120-0859-NA0020-□□	859	1159	47.5	7.6	29
LETLA-C-F35□120-0967-NA0020-□□	967	1267	21.5	7.6	31
LETLA-C-F35□120-1075-NA0020-□□	1075	1375	35.5	7.6	33
LETLA-C-F35□120-1183-NA0020-□□	1183	1483	49.5	7.6	35
LETLA-C-F35□120-1291-NA0020-□□	1291	1591	23.5	7.6	36
LETLA-C-F35□120-1399-NA0020-□□	1399	1699	37.5	7.6	38
LETLA-C-F35□120-1507-NA0020-□□	1507	1807	13.5	7.6	40
LETLA-C-F35□120-1615-NA0020-□□	1615	1915	25.5	7.6	42
LETLA-C-F35□120-1723-NA0020-□□	1723	2023	41.5	7.6	44
LETLA-C-F35□120-1831-NA0020-□□	1831	2131	13.5	7.6	46
LETLA-C-F35□120-1939-NA0020-□□	1939	2239	29.5	7.6	48
LETLA-C-F35□120-2047-NA0020-□□	2047	2347	41.5	7.6	50
LETLA-C-F35□120-2155-NA0020-□□	2155	2455	17.5	7.6	52

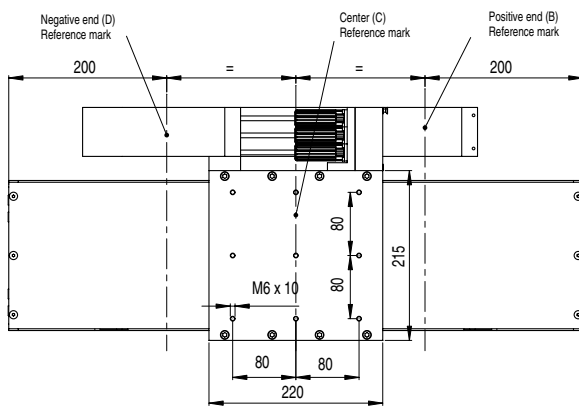
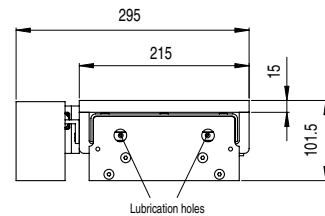
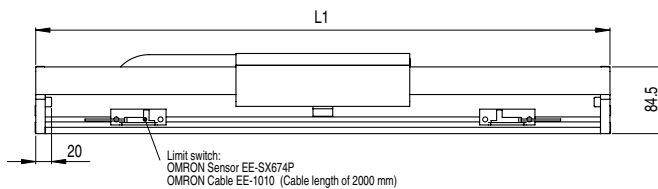
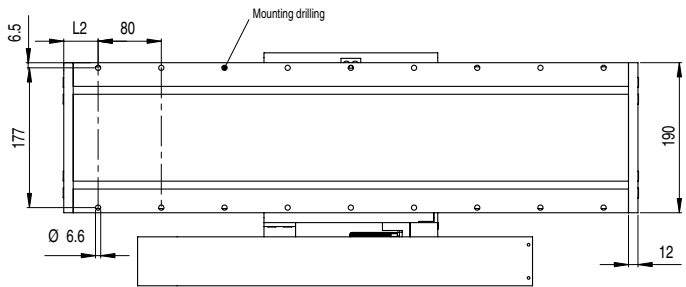

Units: mm

Hall sensor connector



Pin connector type: 7JF-23090-02 (D6C) made by DDK Ltd.

Pin No.	Name
1	+5 V (Power supply)
2	Phase U
3	Phase V
4	Phase W
5	0 V (Power supply)
6	Not used
7	Not used
8	Not used
9	Not used

Linear scale connector



LET adapter type: MA-15BL-15SL

Pin No.	Signal
1	/cos input (V1-)
2	/sin input (V2-)
3	Ref input (V0+)
4	+5 V
5	5 Vs
6	Empty
7	Empty
8	Empty
9	cos input (V1+)
10	sin input (V2+)
11	/Ref input (V0-)
12	0 V
13	0Vs
14	Empty
15	Inner
Case	Shield

Linear servo motor 200V Connector specifications

LETLA-□-F35A120□

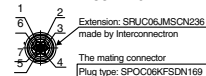

Pin No.	Name
1	Phase U
2	Phase V
3	Phase W
4	Not used
5	Not used
6	FG
7	Not used

Linear servo motor 400V Connector specifications

LETLA-□-F35D120□

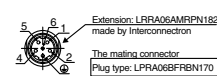

Pin No.	Name
1	Phase U
2	Phase V
3	Phase W
4	Not used
5	Not used
6	Not used
7	Ground

## LETLA-C-F35□230-□

Linear axis model	Effective stroke in mm	L1 in mm	L2 in mm	Weight of moving table including motor coil (kg)	Weight of the complete axis (kg)
LETLA-C-F35□230-0239-NA0020-□C	239	619	17.5	11.5	23
LETLA-C-F35□230-0347-NA0020-□C	347	727	31.5	11.5	25
LETLA-C-F35□230-0455-NA0020-□C	455	835	45.5	11.5	27
LETLA-C-F35□230-0563-NA0020-□C	563	943	19.5	11.5	28
LETLA-C-F35□230-0671-NA0020-□C	671	1051	33.5	11.5	30
LETLA-C-F35□230-0779-NA0020-□C	779	1159	47.5	11.5	32
LETLA-C-F35□230-0887-NA0020-□C	887	1267	21.5	11.5	34
LETLA-C-F35□230-0995-NA0020-□C	995	1375	35.5	11.5	36
LETLA-C-F35□230-1103-NA0020-□C	1103	1483	49.5	11.5	38
LETLA-C-F35□230-1211-NA0020-□C	1211	1591	23.5	11.5	40
LETLA-C-F35□230-1319-NA0020-□C	1319	1699	37.5	11.5	42
LETLA-C-F35□230-1427-NA0020-□C	1427	1807	13.5	11.5	44
LETLA-C-F35□230-1535-NA0020-□C	1535	1915	25.5	11.5	45
LETLA-C-F35□230-1643-NA0020-□C	1643	2023	41.5	11.5	47
LETLA-C-F35□230-1751-NA0020-□C	1751	2131	13.5	11.5	49
LETLA-C-F35□230-1859-NA0020-□C	1859	2239	29.5	11.5	51
LETLA-C-F35□230-1967-NA0020-□C	1967	2347	41.5	11.5	53
LETLA-C-F35□230-2075-NA0020-□C	2075	2455	17.5	11.5	55
LETLA-C-F35□230-2183-NA0020-□C	2183	2563	29.5	11.5	57

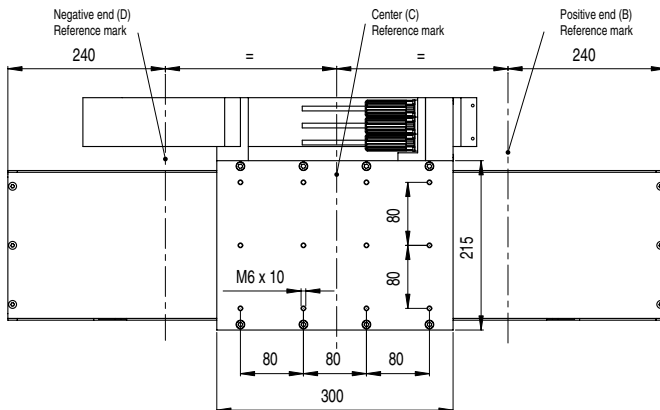
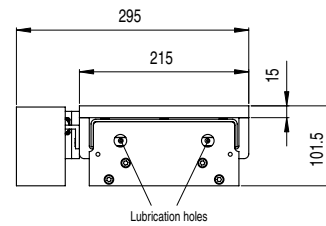
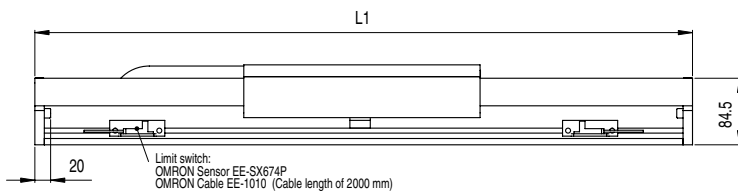
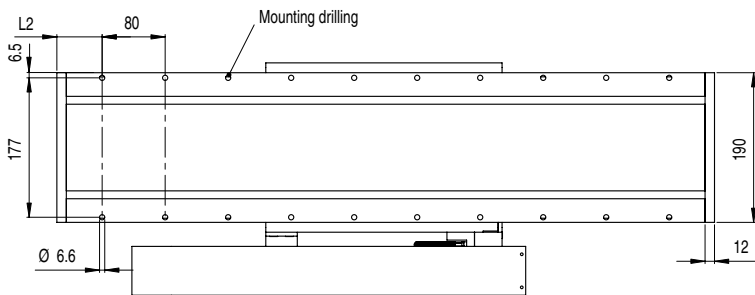

Units: mm

### Hall sensor connector



Pin No.	Name
1	+5 V (Power supply)
2	Phase U
3	Phase V
4	Phase W
5	0 V (Power supply)
6	Not used
7	Not used
8	Not used
9	Not used

Pin connector type:  
7JE-23090-02 (DBC)  
made by DDK Ltd.

### Linear scale connector



Pin No.	Signal
1	/cos input (V1-)
2	/sin input (V2-)
3	Ref input (V0+)
4	+5 V
5	5 Vs
6	Empty
7	Empty
8	Empty
9	cos input (V1+)
10	sin input (V2+)
11	/Ref input (V0-)
12	0 V
13	0 Vs
14	Empty
15	Inner
Case	Shield

LET adapter type:  
MA-15BL-15SL

### Linear servo motor 200 V

#### Connector specifications

#### LETLA-□-F35A230□

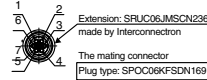

Pin No.	Name
1	Phase U
2	Phase V
3	Phase W
4	Not used
5	Not used
6	FG
7	Not used

Extension: SRJUC06JMSCN236  
made by Interconnectron  
The mating connector  
Plug type: SPOC06KFSDN169

### Linear servo motor 400 V

#### Connector specifications

#### LETLA-□-F35D230□

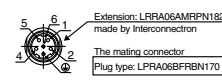

Pin No.	Name
1	Phase U
2	Phase V
3	Phase W
4	Not used
5	Not used
6	Not used
7	Ground

Extension: LPRAO6AMRPN182  
made by Interconnectron  
The mating connector  
Plug type: LPRAO6BFRBN170

LETLA-C-F50□200-□

Linear axis model	Effective stroke in mm	L1 in mm	L2 in mm	Weight of moving table including motor coil (kg)	Weight of the complete axis (kg)
LETLA-C-F50□200-0144-NA0020-□C	144	484	30.0	11.2	25
LETLA-C-F50□200-0414-NA0020-□C	414	754	45.0	11.2	31
LETLA-C-F50□200-0549-NA0020-□C	549	889	32.5	11.2	34
LETLA-C-F50□200-0684-NA0020-□C	684	1024	20.0	11.2	37
LETLA-C-F50□200-0819-NA0020-□C	819	1159	47.5	11.2	40
LETLA-C-F50□200-0954-NA0020-□C	954	1294	35.0	11.2	43
LETLA-C-F50□200-1089-NA0020-□C	1089	1429	22.5	11.2	46
LETLA-C-F50□200-1224-NA0020-□C	1224	1564	50.0	11.2	49
LETLA-C-F50□200-1359-NA0020-□C	1359	1699	37.5	11.2	52
LETLA-C-F50□200-1494-NA0020-□C	1494	1834	25.0	11.2	55
LETLA-C-F50□200-1629-NA0020-□C	1629	1969	12.5	11.2	58
LETLA-C-F50□200-1764-NA0020-□C	1764	2104	40.0	11.2	61
LETLA-C-F50□200-1899-NA0020-□C	1899	2239	27.5	11.2	64
LETLA-C-F50□200-2034-NA0020-□C	2034	2374	15.0	11.2	67
LETLA-C-F50□200-2169-NA0020-□C	2169	2509	42.5	11.2	70

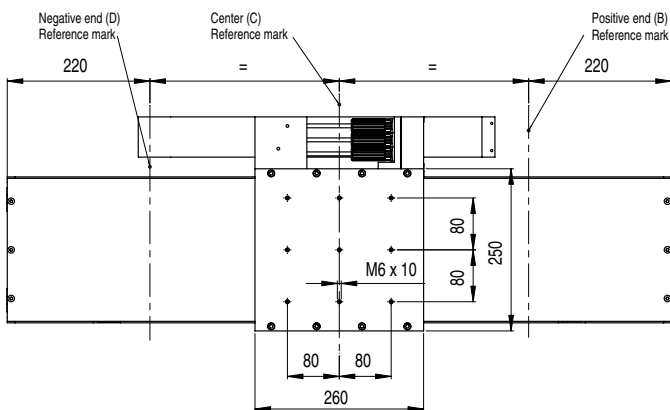
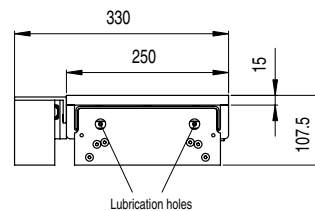
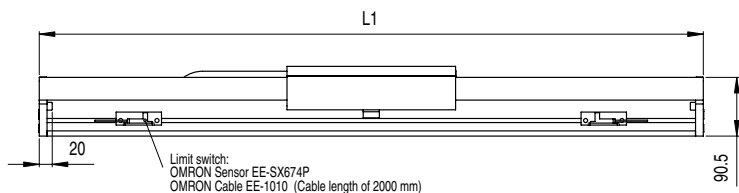
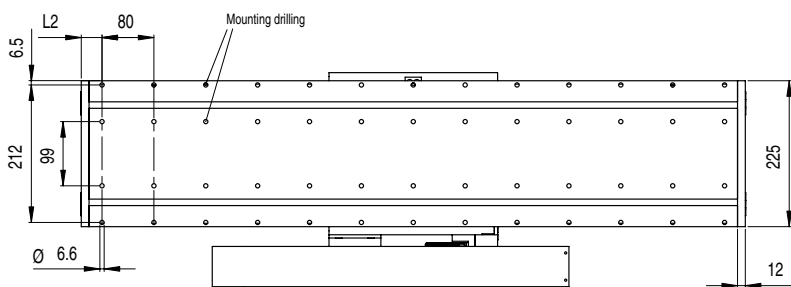

Units: mm

Hall sensor connector



Pin connector type: 7JE-23090-02 (D&C) made by DDK Ltd.

Pin No.	Name
1	+5 V (Power supply)
2	Phase U
3	Phase V
4	Phase W
5	0 V (Power supply)
6	Not used
7	Not used
8	Not used
9	Not used

Linear scale connector



LET adapter type: MA-15BL-15SL

Pin No.	Signal
1	/cos input (V1-)
2	/sin input (V2-)
3	Ref input (V0+)
4	+5 V
5	5 Vs
6	Empty
7	Empty
8	Empty
9	cos input (V1+)
10	sin input (V2+)
11	/Ref input (V0-)
12	0 V
13	0 Vs
14	Empty
15	Inner
Case	Shield

Linear servo motor 200 V Connector specifications

LETLA-□-F50A200□

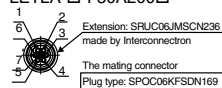

Pin No.	Name
1	Phase U
2	Phase V
3	Phase W
4	Not used
5	Not used
6	FG
7	Not used

Linear servo motor 400 V Connector specifications

LETLA-□-F50D200□

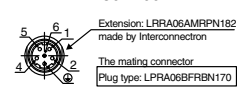

Pin No.	Name
1	Phase U
2	Phase V
3	Phase W
4	Not used
5	Not used
6	Not used
⊕	Ground

## LETLA-C-F50□380-□

Linear axis model	Effective stroke in mm	L1 in mm	L2 in mm	Weight of moving table including motor coil (kg)	Weight of the complete axis (kg)
LETLA-C-F50□380-0214-NA0020-□C	214	754	45.0	22.5	40
LETLA-C-F50□380-0349-NA0020-□C	349	889	32.5	22.5	43
LETLA-C-F50□380-0484-NA0020-□C	484	1024	20.0	22.5	46
LETLA-C-F50□380-0619-NA0020-□C	619	1159	47.5	22.5	49
LETLA-C-F50□380-0754-NA0020-□C	754	1294	35.0	22.5	52
LETLA-C-F50□380-0889-NA0020-□C	889	1429	22.5	22.5	55
LETLA-C-F50□380-1024-NA0020-□C	1024	1564	50.0	22.5	58
LETLA-C-F50□380-1159-NA0020-□C	1159	1699	37.5	22.5	61
LETLA-C-F50□380-1294-NA0020-□C	1294	1834	25.0	22.5	64
LETLA-C-F50□380-1429-NA0020-□C	1429	1969	12.5	22.5	67
LETLA-C-F50□380-1564-NA0020-□C	1564	2104	40.0	22.5	70
LETLA-C-F50□380-1699-NA0020-□C	1699	2239	27.5	22.5	74
LETLA-C-F50□380-1834-NA0020-□C	1834	2374	15.0	22.5	77
LETLA-C-F50□380-1969-NA0020-□C	1969	2509	42.5	22.5	80
LETLA-C-F50□380-2104-NA0020-□C	2104	2644	30.0	22.5	83

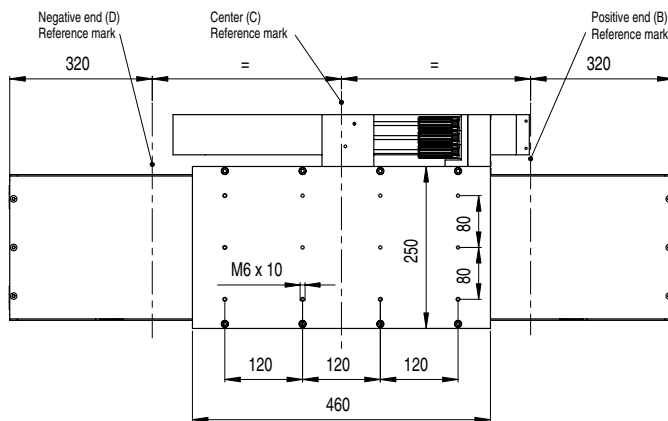
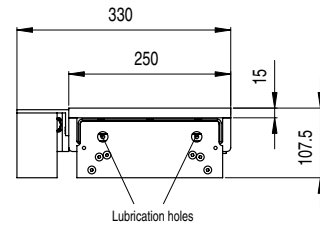
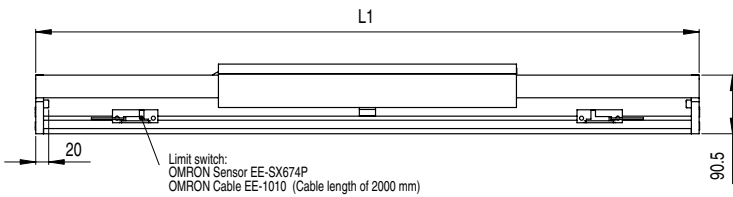
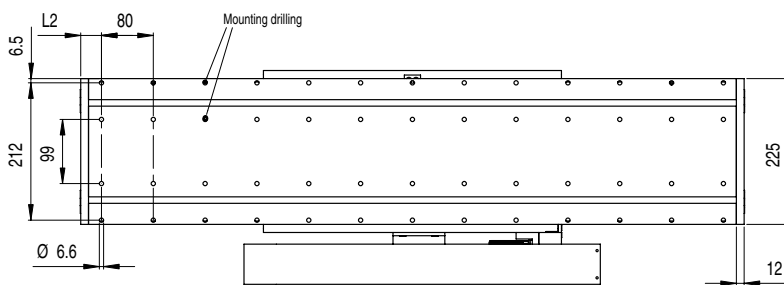

Units: mm

### Hall sensor connector



Pin connector type: 7JE-23090-02 (D8C) made by DDK Ltd.

Pin No.	Name
1	+5 V (Power supply)
2	Phase U
3	Phase V
4	Phase W
5	0 V (Power supply)
6	Not used
7	Not used
8	Not used
9	Not used

### Linear scale connector



LET adapter type: MA-15BL-15SL

Pin No.	Signal
1	/cos input (V1-)
2	/sin input (V2-)
3	Ref input (V0+)
4	+5 V
5	5 Vs
6	Empty
7	Empty
8	Empty
9	cos input (V1+)
10	sin input (V2+)
11	/Ref input (V0-)
12	0 V
13	0 Vs
14	Empty
15	Inner
Case	Shield

### Linear servo motor 200 V

#### Connector specifications

#### LETLA-□-F50A380□

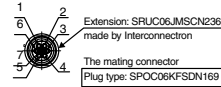

Pin No.	Name
1	Phase U
2	Phase V
3	Phase W
4	Not used
5	Not used
6	FG
7	Not used

### Linear servo motor 400 V

#### Connector specifications

#### LETLA-□-F50D380□

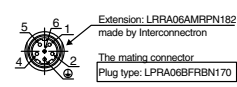

Pin No.	Name
1	Phase U
2	Phase V
4	Phase W
5	Not used
6	Not used
⊕	Ground



LETLA-C-F1Z□200-□

Linear axis model	Effective stroke in mm	L1 in mm	L2 in mm	Weight of moving table including motor coil (kg)	Weight of the complete axis (kg)
LETLA-C-F1Z□200-0104-NA0020-□C	104	484	30.0	18	37
LETLA-C-F1Z□200-0374-NA0020-□C	374	754	45.0	18	47
LETLA-C-F1Z□200-0509-NA0020-□C	509	889	32.5	18	52
LETLA-C-F1Z□200-0644-NA0020-□C	644	1024	20.0	18	57
LETLA-C-F1Z□200-0779-NA0020-□C	779	1159	47.5	18	62
LETLA-C-F1Z□200-0914-NA0020-□C	914	1294	35.0	18	67
LETLA-C-F1Z□200-1049-NA0020-□C	1049	1429	22.5	18	72
LETLA-C-F1Z□200-1184-NA0020-□C	1184	1564	50.0	18	77
LETLA-C-F1Z□200-1319-NA0020-□C	1319	1699	37.5	18	82
LETLA-C-F1Z□200-1454-NA0020-□C	1454	1834	25.0	18	87
LETLA-C-F1Z□200-1589-NA0020-□C	1589	1969	12.5	18	92
LETLA-C-F1Z□200-1724-NA0020-□C	1724	2104	40.0	18	97
LETLA-C-F1Z□200-1859-NA0020-□C	1859	2239	27.5	18	102
LETLA-C-F1Z□200-1994-NA0020-□C	1994	2374	15.0	18	107
LETLA-C-F1Z□200-2129-NA0020-□C	2129	2509	42.5	18	111

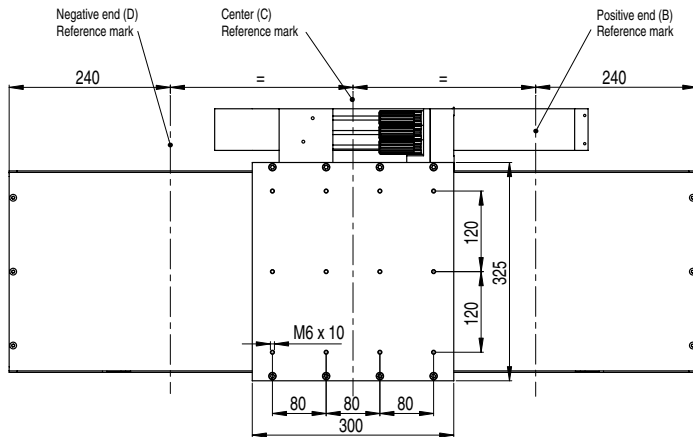
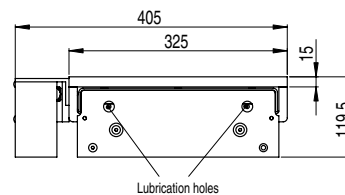
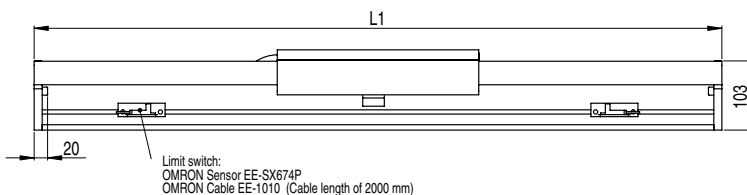
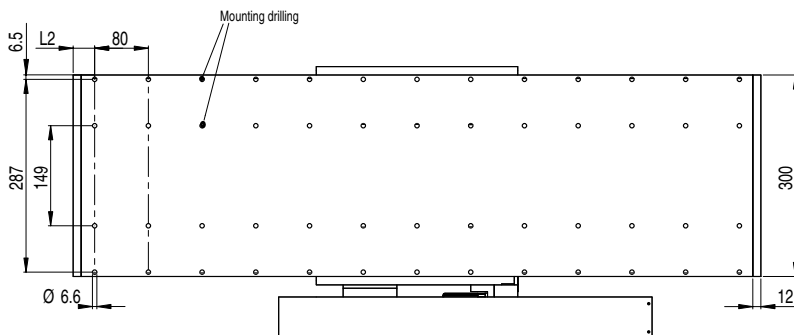

Units: mm

Hall sensor connector



Pin connector type: 7JE-23090-02 (D8C) made by DDK Ltd.

Pin No.	Name
1	+5 V (Power supply)
2	Phase U
3	Phase V
4	Phase W
5	0 V (Power supply)
6	Not used
7	Not used
8	Not used
9	Not used

Linear scale connector



LET adapter type: MA-15BL-15SL

Pin No.	Signal
1	/cos input (V1-)
2	/sin input (V2-)
3	Ref input (V0+)
4	+5 V
5	5 Vs
6	Empty
7	Empty
8	Empty
9	cos input (V1+)
10	sin input (V2+)
11	/Ref input (V0-)
12	0 V
13	0 Vs
14	Empty
15	Inner
Case	Shield

Linear servo motor 200 V Connector specifications

LETLA-□-F1ZA200□

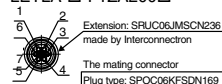

Pin No.	Name
1	Phase U
2	Phase V
3	Phase W
4	Not used
5	Not used
6	FG
7	Not used

Linear servo motor 400 V Connector specifications

LETLA-□-F1ZD200□

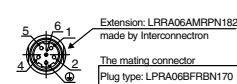

Pin No.	Name
1	Phase U
2	Phase V
4	Phase W
5	Not used
6	Not used
⊕	Ground

## LETLA-C-F1ZD380-□

Linear axis model	Effective stroke in mm	L1 in mm	L2 in mm	Weight of moving table including motor coil (kg)	Weight of the complete axis (kg)
LETLA-C-F1ZD380-0184-NA0020-□C	184	754	45.0	31	60
LETLA-C-F1ZD380-0319-NA0020-□C	319	889	32.5	31	65
LETLA-C-F1ZD380-0454-NA0020-□C	454	1024	20.0	31	70
LETLA-C-F1ZD380-0589-NA0020-□C	589	1159	47.5	31	75
LETLA-C-F1ZD380-0724-NA0020-□C	724	1294	35.0	31	80
LETLA-C-F1ZD380-0859-NA0020-□C	859	1429	22.5	31	84
LETLA-C-F1ZD380-0994-NA0020-□C	994	1564	50.0	31	89
LETLA-C-F1ZD380-1129-NA0020-□C	1129	1699	37.5	31	94
LETLA-C-F1ZD380-1264-NA0020-□C	1264	1834	25.0	31	99
LETLA-C-F1ZD380-1399-NA0020-□C	1399	1969	12.5	31	104
LETLA-C-F1ZD380-1534-NA0020-□C	1534	2104	40.0	31	109
LETLA-C-F1ZD380-1669-NA0020-□C	1669	2239	27.5	31	114
LETLA-C-F1ZD380-1804-NA0020-□C	1804	2374	15.0	31	119
LETLA-C-F1ZD380-1939-NA0020-□C	1939	2509	42.5	31	124
LETLA-C-F1ZD380-2074-NA0020-□C	2074	2644	30.0	31	129

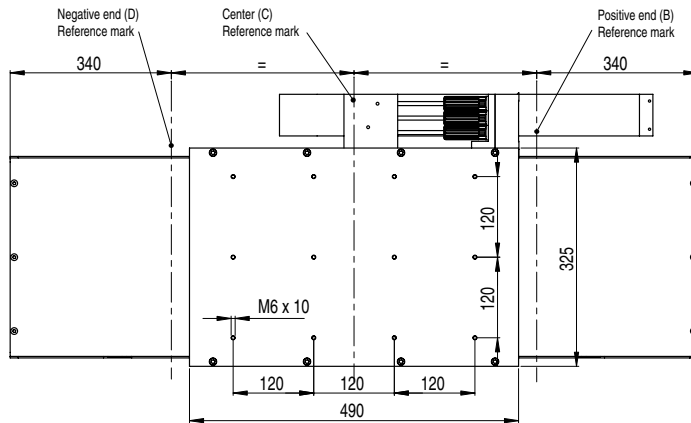
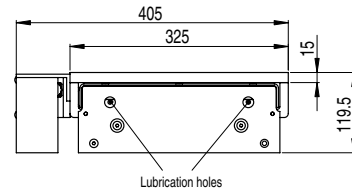
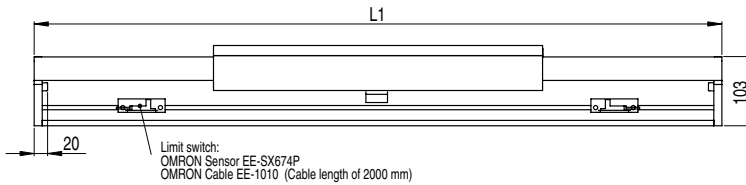
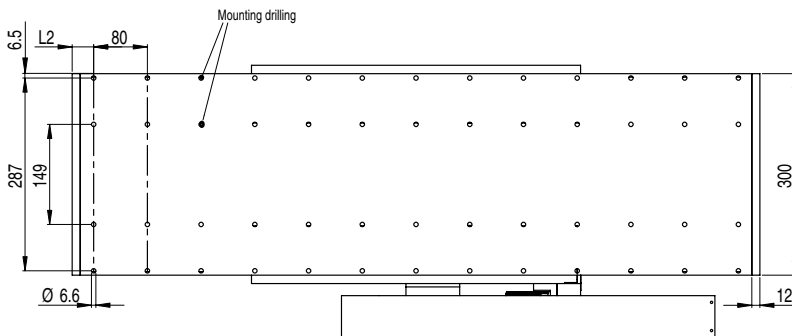

Units: mm

### Hall sensor connector



Pin connector type:  
7JE-23090-02 (D8C)  
made by DDK Ltd.

Pin No.	Name
1	+5 V (Power supply)
2	Phase U
3	Phase V
4	Phase W
5	0 V (Power supply)
6	Not used
7	Not used
8	Not used
9	Not used

### Linear scale connector



LET adapter type:  
MA-15BL-15SL

Pin No.	Signal
1	/cos input (V1-)
2	/sin input (V2-)
3	Ref input (V0+)
4	+5 V
5	5 Vs
6	Empty
7	Empty
8	Empty
9	cos input (V1+)
10	sin input (V2+)
11	/Ref input (V0-)
12	0 V
13	0 Vs
14	Empty
15	Inner
Case	Shield

### Linear servo motor 400 V Connector specifications

#### LETLA-□-F1ZD380□

Extension: LPRAO6AMFPN182  
made by Interconnector  
The mating connector  
Plug type: LPRAO6BFRBN170

Pin No.	Name
1	Phase U
2	Phase V
4	Phase W
5	Not used
6	Not used
⊕	Ground

Serial converter unit

JZDP-[A/D]008-□□□

Items	Specifications	
Electrical characteristics	Power supply voltage	+5.0 V ±5%, ripple content 5% max.
	Current consumption	120 mA Typ. 350 mA Max.
	Signal resolution	Input 2-phase sine wave: 1/256 pitch
	Max. response frequency	250 kHz
	Analog input signals (cos, sin, Ref)	Differential input amplitude: 0.4 V to 1.2 V Input signal level: 1.5 V to 3.5 V
	Pole sensor input signal	CMOS level
	Output signals	Position data, hall sensor information, and alarms
	Output method	Serial data transmission (HDLC (High-level data link control) protocol format with Manchester codes)
	Transmission cycle	62.5 μs
	Output circuit	Balanced transceiver (SN75LBC176 or the equivalent) Internal terminal resistance: 120 Ω
Mechanical characteristics	Approx. mass	150 g
	Vibration resistance	98 m/s <sup>2</sup> max. (1 to 2500 Hz) in three directions
	Shock resistance	980 m/s <sup>2</sup> , (11 ms) two times in three directions
Environmental conditions	Operating temperature	0 °C to 55 °C (32 to 131 °F)
	Storage temperature	-20 °C to +80 °C (-4 to +176 °F)
	Humidity	20% to 90%RH (without condensation)

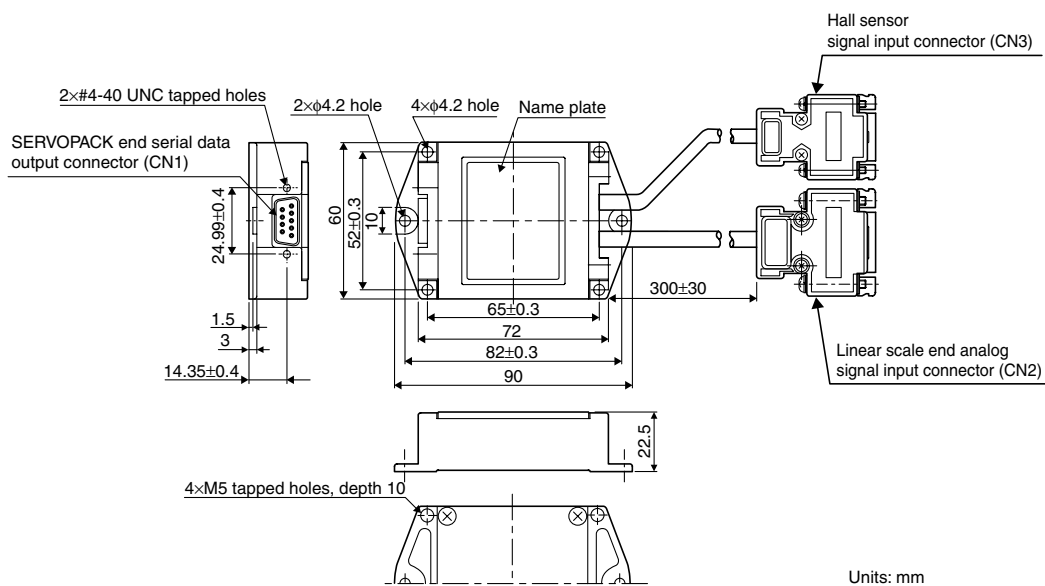

Units: mm

**CN1**  
SERVOPACK end serial data output

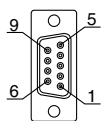

Pin No.	Signal
1	+5 V
2	S-phase output
3	Empty
4	Empty
5	0 V
6	/S-phase output
7	Empty
8	Empty
9	Empty
Case	Shield

**CN2**  
Linear scale end Analog signal input

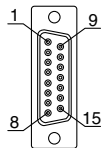

Pin No.	Signal
1	/cos input (V1-)
2	/sin input (V2-)
3	Ref input (V0+)
4	+5 V
5	5 Vs
6	Empty
7	Empty
8	Empty
9	cos input (V1+)
10	sin input (V2+)
11	/Ref input (V0-)
12	0 V
13	0 Vs
14	Empty
15	Inner shield
Case	Shield

**CN3**  
Hall sensor signal input

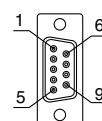

Pin No.	Signal
1	+5 V
2	U-phase input
3	V-phase input
4	W-phase input
5	0 V
6	Empty
7	Empty
8	Empty
9	Empty
Case	Shield

Ordering information

(Refer to Servo Drive chapter)

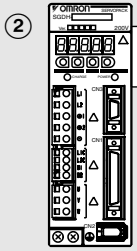

② Servo Drive with option boards for flexible system configuration

Sigma-II Servo Drive

Drive options

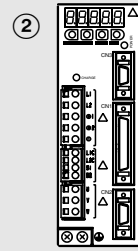

② Intelligent Servo Drive

XtraDrive

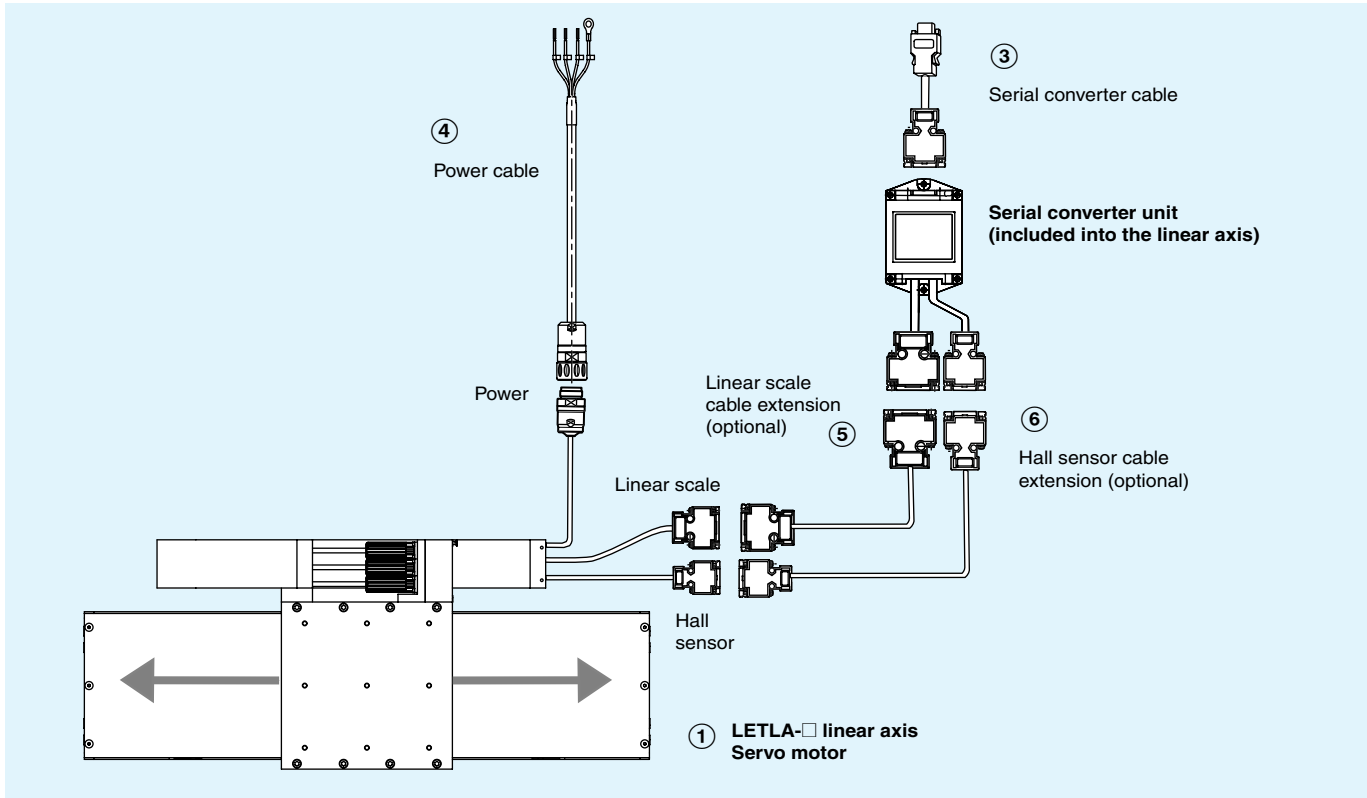

**Note:** The symbols ①②③... show the recommended sequence to select the servomotor, cables and serial converter for a linear motors system.

Linear motor axis

LETLA-C-F□

230 VAC single phase

Symbol	Specifications		Model		
	Rated force	Peak force	① Linear axis model	② Servo drive	
				Sigma-II series	XtraDrive
①②	80 N	220 N	LETLA-C-F35A120-[stroke]-NA0020-DC	SGDH-02AE-OY	XD-02-MN01
	160 N	440 N	LET-A-C-F35A230-[stroke]-NA0020-DC	SGDH-08AE-S-OY	XD-08-MN
	280 N	600 N	LETLA-C-F50A200-[stroke]-NA0020-DC	SGDH-08AE-S-OY	XD-08-MN
	560 N	1200 N	LETLA-C-F50A380-[stroke]-NA0020-DC	SGDH-15AE-S-OY	XD-15-MN
	560 N	1200 N	LETLA-C-F1ZA200-[stroke]-NA0020-DC	SGDH-15AE-S-OY	XD-15-MN

**Note:** For effective stroke distances available see dimensions section.

400 VAC three phase

Symbol	Specifications		Model		
	Rated force	Peak force	① Linear axis model	② Servo drive	
				Sigma-II series	XtraDrive
①②	80 N	220 N	LETLA-C-F35D120-[stroke]-NA0020-DC	SGDH-05DE-OY	XD-05-TN
	160 N	440 N	LETLA-C-F35D230-[stroke]-NA0020-DC	SGDH-05DE-OY	XD-05-TN
	280 N	600 N	LETLA-C-F50D200-[stroke]-NA0020-DC	SGDH-10DE-OY	XD-10-TN
	560 N	1200 N	LETLA-C-F50D380-[stroke]-NA0020-DC	SGDH-15DE-OY	XD-15-TN
	560 N	1200 N	LETLA-C-F1ZD200-[stroke]-NA0020-DC	SGDH-15DE-OY	XD-15-TN
	1120 N	2400 N	LETLA-C-F1ZD380-[stroke]-NA0020-DC	SGDH-30DE-OY	XD-30-TN

Note: For effective stroke distances available see dimensions section.

Servo drive

Note: Choosing sigma-II drive or XtraDrive affects to the serial converter cable needed.

② Refer to sigma-II servo drive or XtraDrive chapter for detailed drive specifications and selection of drive accessories.

Serial converter cable to servo drive

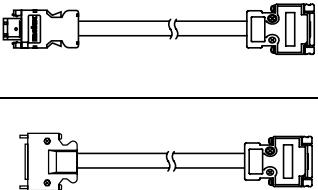
Symbol	Specifications	Model	Appearance	
③	Sigma-II drive to serial converter cable	3 m	JZSP-CLP70-03-E	
		5 m	JZSP-CLP70-05-E	
		10 m	JZSP-CLP70-10-E	
		15 m	JZSP-CLP70-15-E	
		20 m	JZSP-CLP70-20-E	
	XtraDrive drive to serial converter cable	3 m	XD-CLP70-03-E	
		5 m	XD-CLP70-05-E	
		10 m	XD-CLP70-10-E	
		15 m	XD-CLP70-15-E	
		20 m	XD-CLP70-20-E	

Power cables

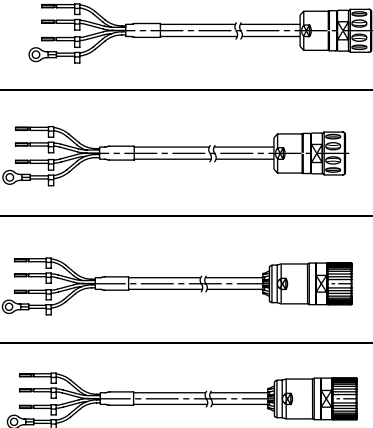
Symbol	Specifications	Model	Appearance	
④	For 200 V servo motors LETLA-□-F35A□	3 m	R88A-CAWA003S-DE	
		5 m	R88A-CAWA005S-DE	
		10 m	R88A-CAWA010S-DE	
		15 m	R88A-CAWA015S-DE	
		20 m	R88A-CAWA020S-DE	
	For 200 V servo motors LETLA-□-F50A□ LETLA-□-F1ZA200□	3 m	R88A-CAWB003S-DE	
		5 m	R88A-CAWB005S-DE	
		10 m	R88A-CAWB010S-DE	
		15 m	R88A-CAWB015S-DE	
		20 m	R88A-CAWB020S-DE	
	For 400 V servo motors LETLA-□-F35D□ LETLA-□-F50D200D□	3 m	R88A-CAWK003S-DE	
		5 m	R88A-CAWK005S-DE	
		10 m	R88A-CAWK010S-DE	
		15 m	R88A-CAWK015S-DE	
		20 m	R88A-CAWK020S-DE	
	For 400 V servo motors LETLA-□-F50D380□ LETLA-□-F1ZD□	3 m	R88A-CAWL003S-DE	
		5 m	R88A-CAWL005S-DE	
		10 m	R88A-CAWL010S-DE	
		15 m	R88A-CAWL015S-DE	
		20 m	R88A-CAWL020S-DE	

Linear scale cable to serial converter

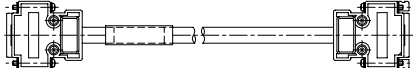
Symbol	Specifications	Model	Appearance	
⑤	Extension cable linear scale to serial converter. (Connector DB-15) (The extension cable is optional)	1 m	JZSP-CLL00-01-E	
		3 m	JZSP-CLL00-03-E	
		5 m	JZSP-CLL00-05-E	
		10 m	JZSP-CLL00-10-E	
		15 m	JZSP-CLL00-15-E	

Hall sensor cable to serial converter

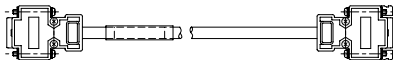
Symbol	Specifications	Model	Appearance	
⑥	Extension cable for linear scale to serial converter. (The extension cable is optional)	1 m	JZSP-CLL10-01-E	
		3 m	JZSP-CLL10-03-E	
		5 m	JZSP-CLL10-05-E	
		10 m	JZSP-CLL10-10-E	
		15 m	JZSP-CLL10-15-E	

Connectors

Specification	Model
Hypertac power connector IP67 (for 200 V motors)	SPOC-06K-FSDN169
Hypertac power connector IP67 (for 400 V motors)	LPRA-06B-FRBN170

ALL DIMENSIONS SHOWN ARE IN MILLIMETERS.

To convert millimeters into inches, multiply by 0.03937. To convert grams into ounces, multiply by 0.03527.