

CJ1W-NCF71 - MECHATROLINK-II

Position control unit

Multi-axes position controller via high-speed MECHATROLINK-II

- Up to 16 axes controlled with minimum wiring. Only one cable between devices is needed.
- High-speed bus MECHATROLINK-II is specially designed for motion control
- Supports position, speed and torque control.
- Programming languages: ladder, function blocks.
- Smart active parts for OMRON HMI's terminals reduce engineering time.
- Access to the complete system from one point. Network setup, servo drives configuring and monitoring, and PLC programming.



System configuration

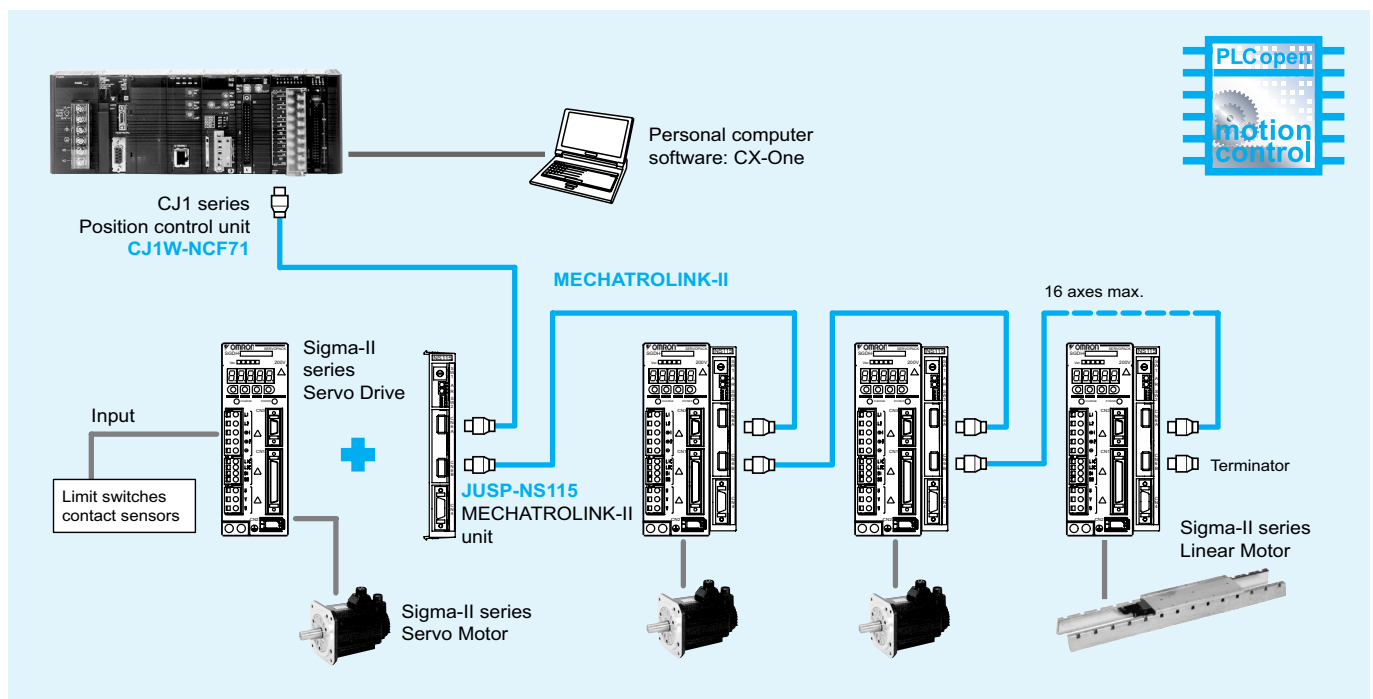

Specifications

Position control unit

Model		CJ1W-NCF71
Classification		CJ-series CPU bus unit
Applicable PLCs		CJ-series CJ-series V. 3.0 or later in order to use function blocks (recommended CJ1G-CPU45 or CJ1H-CPU□)
Possible unit number settings		0 to F
Control method		MECHATROLINK-II (position, speed and torque control)
Controlled devices		Sigma-II series servo drives (ver. 38 or later) with MECHATROLINK-II interface
Controlled axes		16 maximum
I/O allocations	Common operating memory area	Words allocated in CPU bus unit area: 25 words (15 output words, 10 input words)
	Axis operating memory area	Allocated in one of the following areas (user-specified): CIO, work, auxiliary, holding, DM, or EM area. Number of words allocated: 50 words (25 output words, 25 input words) × highest axis No. used
Control units	Position command unit	Command unit: depends on the electronic gear setting in the servo parameters. Default setting: pulses
	Speed command unit for position control	Command units/s
	Acceleration/deceleration speeds for position control	10,000 command units/s ²
	Speed command unit for speed control	0.001% of the motor's maximum speed
	Torque command unit for torque control	0.001% of the motor's maximum torque
Control command range	Position command range	-2,147,483,648 to 2,147,483,647 (command units)
	Speed command range for position control	0 to 2,147,483,647 (command units/s)
	Acceleration/deceleration speeds for position control	1 to 65,535 (10,000 command units/s ²)
	Speed command range for speed control	-199.999% to 199.999% The upper limit is restricted by the maximum speed of the servo motor.
	Torque command range for torque control	-199.999% to 199.999% The upper limit is restricted by the maximum torque of the servo motor.
Control functions	Servo lock/unlock	Locks and unlocks the servo driver.
	Position control	Positions to an absolute position or relative position according to the specified target position and target speed specified from the ladder program.
	Origin determination	<ul style="list-style-type: none"> • Origin search: establishes the origin using the specified search method. • Present position preset: changes the present position to a specified position to establish the origin. • Origin return: returns the axis from any position to the established origin. • Absolute encoder origin: establishes the origin using a servo motor that has an absolute encoder, without having to use an origin search.
	Jogging	Outputs a fixed speed in the CW or CCW direction.
	Interrupt feeding	Performs positioning by moving the axis a fixed amount when an external interrupt input is received while the axis is moving.
	Speed control	Performs speed control by sending a command to the servo driver speed loop.
	Torque control	Performs torque control by sending a command to the servo driver current loop.
	Stop functions	<ul style="list-style-type: none"> • Deceleration stop: decelerates the moving axis to a stop. • Emergency stop: positions the moving axis for the number of pulses remaining in the deviation counter and then stops the axis.
	Linear interpolation	Up to 8 axes can be interpolated by using two interpolators (4 axes per interpolator) Available in unit version 1.1 or higher
	Auxiliary functions	Acceleration/deceleration curves
	Torque limit	Restricts the torque upper limit during position control.
	Override	Multiplies the axis command speed by a specified ratio. Override: 0.01% to 327.67%
	Servo parameter transfer	Reads and writes the servo driver parameters from the ladder program in the CPU unit.
	Monitoring function	Monitors the control status of the servo driver's command coordinate positions, feedback position, current speed, torque, etc.
	Software limits	Limits software operation for controlling positioning.
	Backlash compensation	Compensates for the amount of play in the mechanical system according to a set value.
External I/O	Position control unit	One MECHATROLINK-II interface port
	Servo driver I/O	CW/CCW limit inputs, origin proximity inputs, external interrupt inputs 1 to 3 (can be used as external origin inputs)
Programming methods	Standard ladder	Directly over NCF unit memory area
	Function blocks	Using standard PLC open function blocks
	Smart active parts	Use of OMRON HMIs smart active parts optimizes CPU usage and engineering time
Internal current consumption		360 mA or less for 5 VDC
Weight		95 g



JUSP-NS115 - MECHATROLINK-II interface unit

Item	Details	
Type	JUSP-NS115	
Applicable servo drive	SGDH-□□□E models (version 38 or later)	
Installation method	Mounted on the SGDh servo drive side: CN10.	
Basic specifications	Power supply method	Supplied from the servo drive control power supply.
	Power consumption	2 W
MECHATROLINK -II communications	Baud rate/transmission cycle	10 MHz / 0.5 ms or more. MECHATROLINK-II communications
Command format	Operation specification	Positioning using MECHATROLINK-I/II communications.
	Reference input	MECHATROLINK-I/II communications Commands: position, speed, torque, parameter read/write, monitor output
Position control functions	Acceleration/deceleration method	Linear first/second-step, asymmetric, exponential, S-curve
	Fully closed control	Position control with fully closed feedback is possible.
Fully closed system specifications	Encoder pulse output in the servo drive	5 V differential line-driver output (complies with EIA standard RS-422A)
	Fully closed encoder pulse signal	A quad B line-driver
	Maximum receivable frequency for servo drive	1 Mpps
	Power supply for fully closed encoder	To be prepared by customer.
Input signals in the servo drive	Signal allocation changes possible	Forward/reverse run prohibited, zero point return deceleration LS External latch signals 1, 2, 3 Forward/reverse torque control
	Internal functions	Position data latch function
Protection		Parameters damage, parameter setting errors, communications errors, WDT errors, fully closed encoder detecting disconnection
	LED indicators	A: alarm, R: MECHATROLINK-I/II communicating

Nomenclature

CJ1W-NCF71 - position control unit

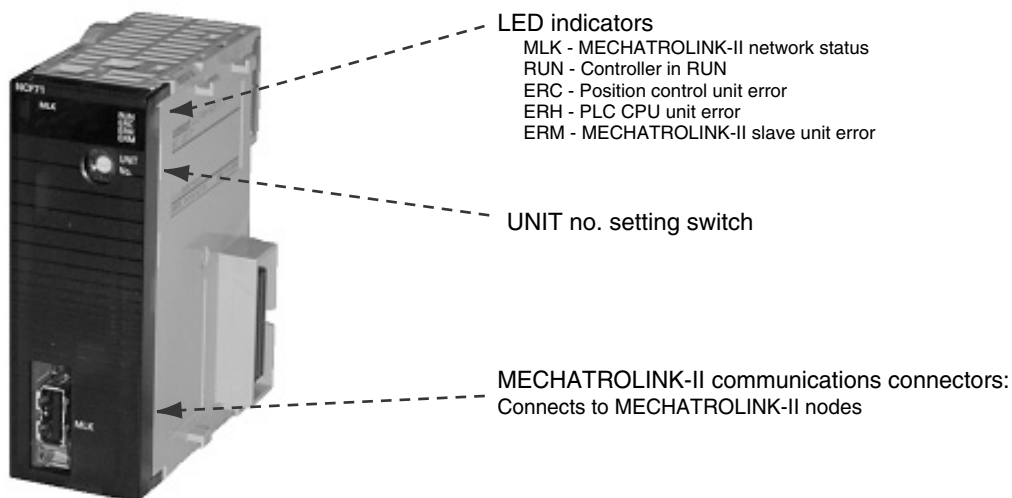

JUSP-NS115 - MECHATROLINK-II interface unit

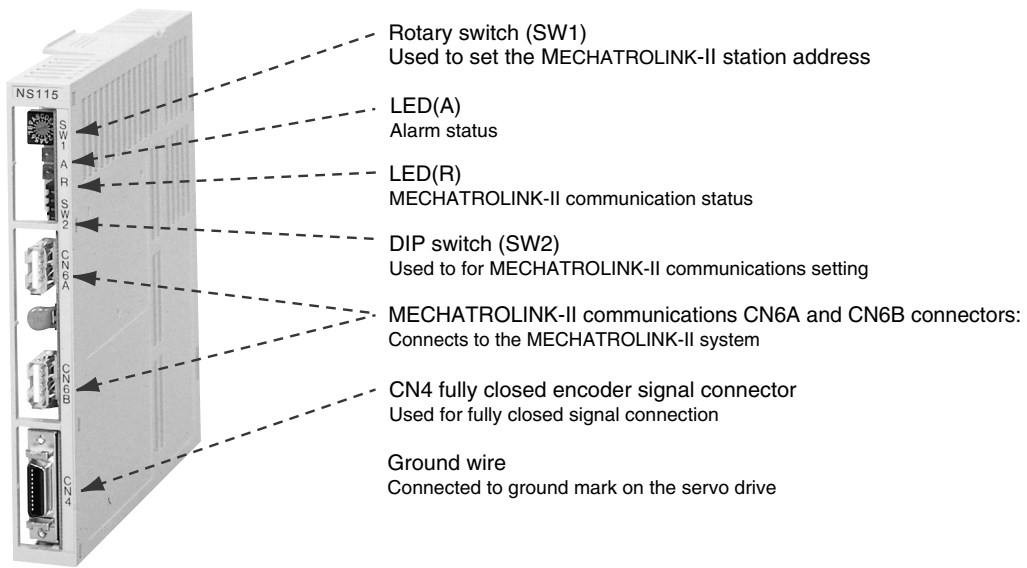

Dimensions

CJ1W-NCF71 - position control unit

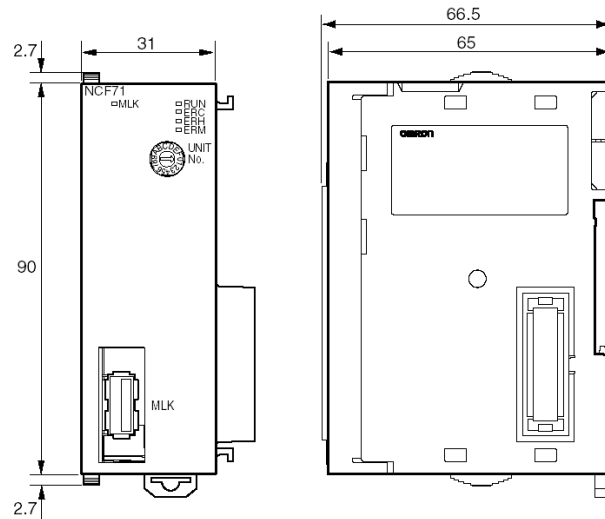

JUSP-NS115 - MECHATROLINK-II interface unit

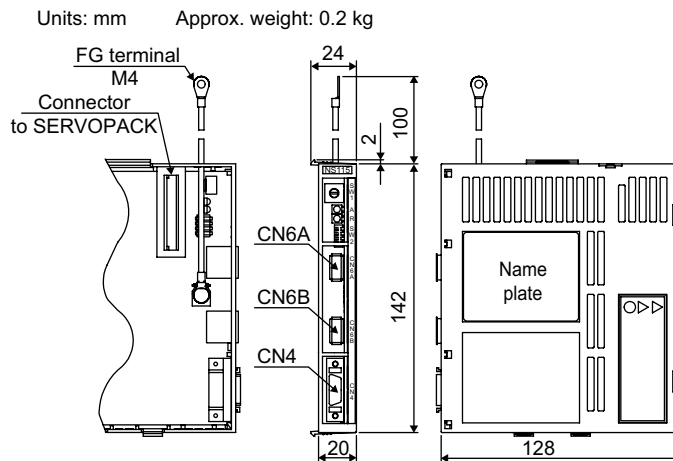

Installation

MECHATROLINK-II interface connections

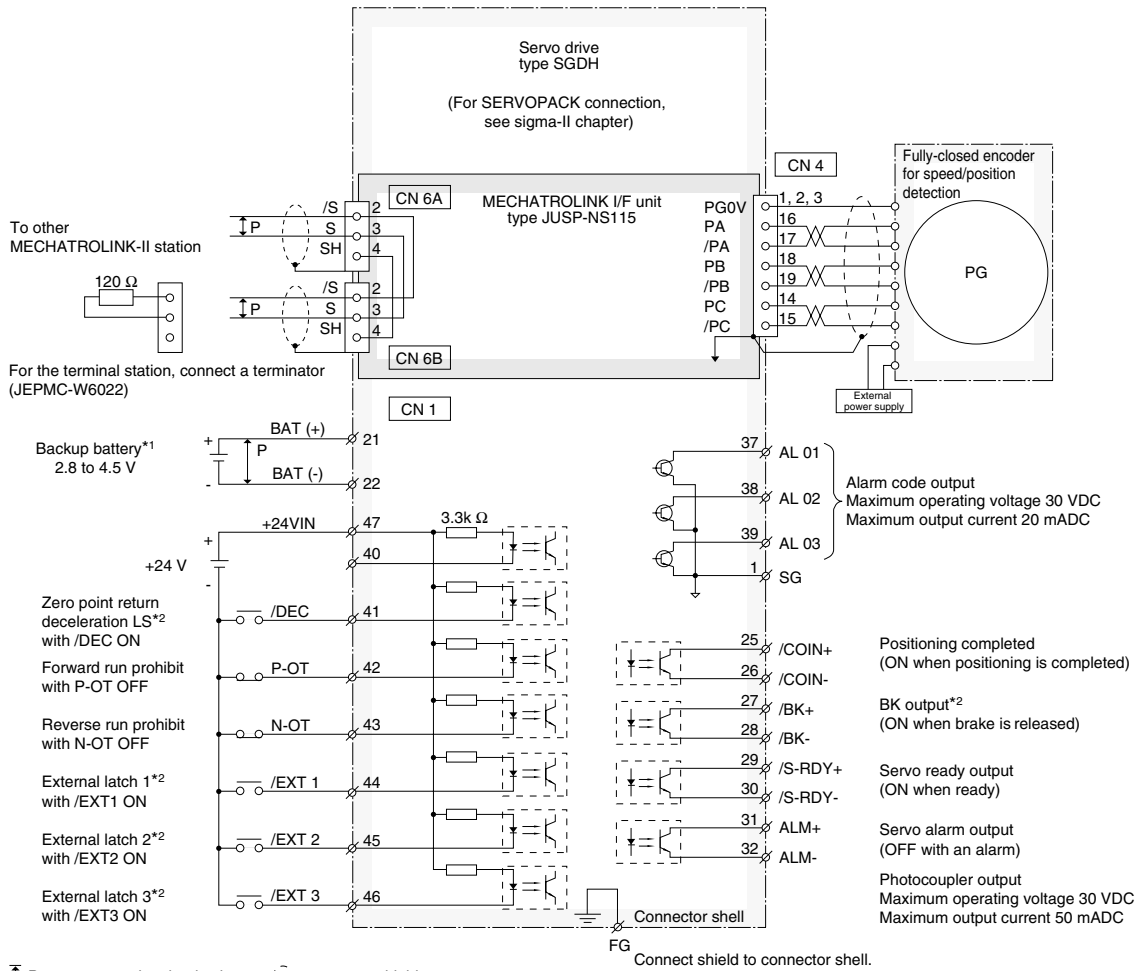

*1 Connect when using an absolute encoder and when the battery is not connected to CN8.
 *2 Set the signal assignment with the user constants.

Ordering information

Position controller unit

Name	Model
MECHATROLINK-II position controller unit	CJ1W-NCF71

MECHATROLINK-II related devices

Name	Remarks	Model
MECHATROLINK-II interface unit	For Sigma-II series servo drives. (Firmware version 38 or later)	JUSP-NS115
MECHATROLINK-II terminator	Terminating resistor	JEPMC-W6022
MECHATROLINK-II cables	0.5 meter	JEPMC-W6003-A5
	1 meter	JEPMC-W6003-01
	3 meters	JEPMC-W6003-03
	5 meters	JEPMC-W6003-05
	10 meters	JEPMC-W6003-10
	20 meters	JEPMC-W6003-20
	30 meters	JEPMC-W6003-30

Servo system

Note: Refer to servo systems section for more information

Computer software

Specifications	Model
CX-One version 1.1 or higher	CX-One

ALL DIMENSIONS SHOWN ARE IN MILLIMETERS.

To convert millimeters into inches, multiply by 0.03937. To convert grams into ounces, multiply by 0.03527.